

BODY
 107' ASL Tandem Axle Aluminum Body
COMPT, LEFT SIDE FRONT
 FH/FD RollUp Forward w/o Chute
COMPT, LEFT SIDE REAR
 FH/FD RollUp and Lift-up Rearward
COMPT, RIGHT SIDE FRONT
 Full Height RollUp Forward
COMPT, RIGHT SIDE REAR
 Full Height RollUp and Lift-up Rearward

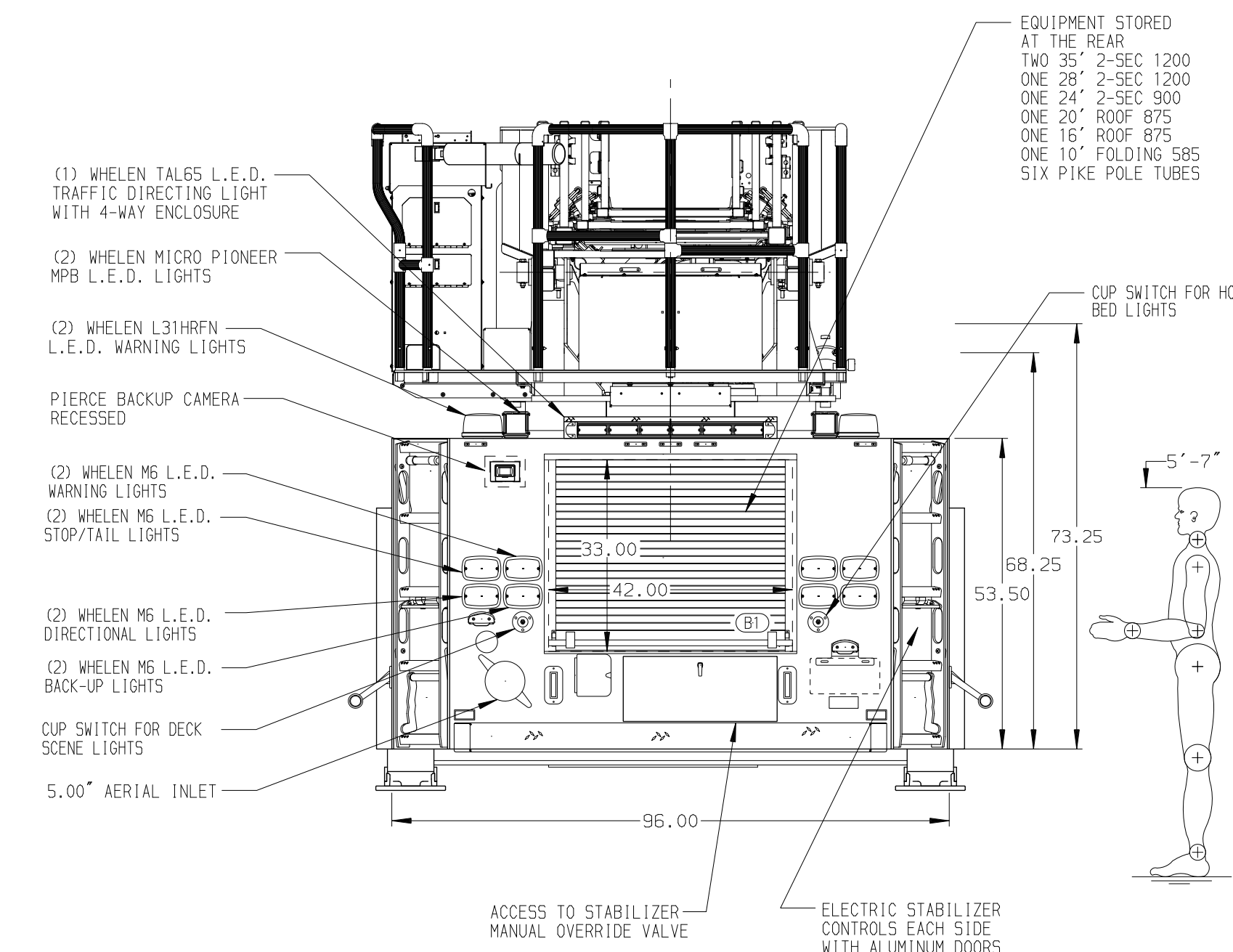
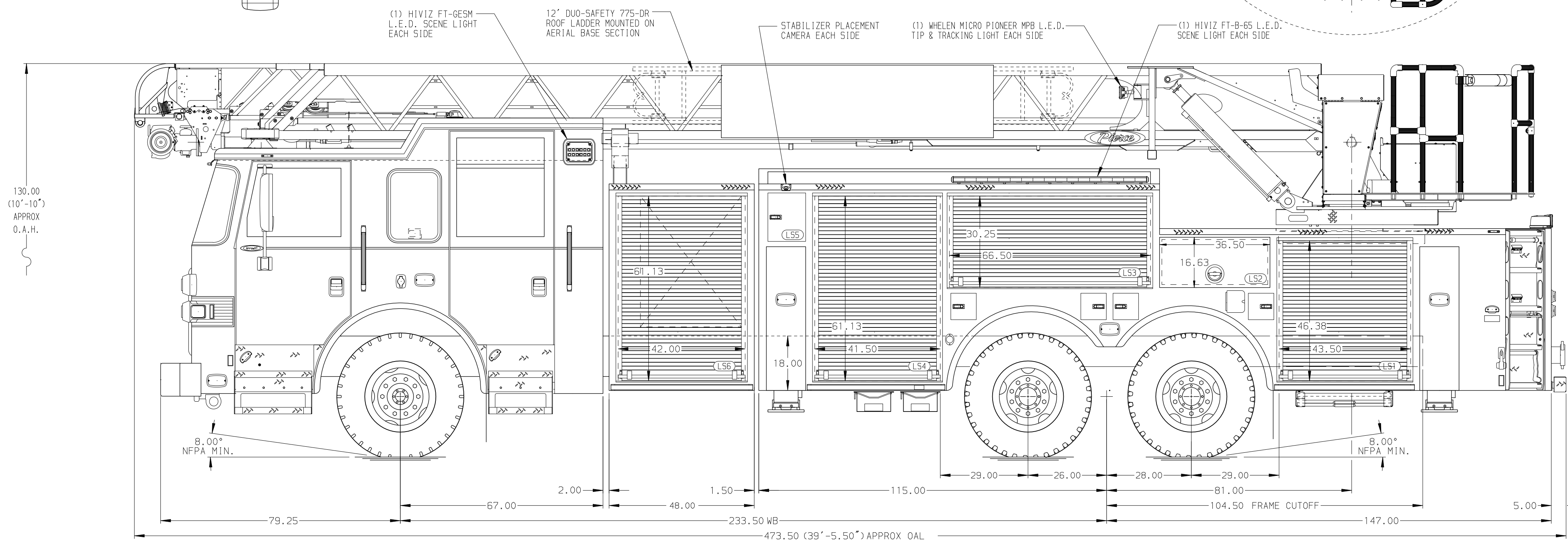

CHASSIS Arrow XT Chassis ENGINE 510 HP Paccor MX13 Engine	CAB 6710 Deep Notched Arrow XT Cab BUMPER 10\" Extended Painted Steel	AXLE, FRONT, CUSTOM 21,500 Lb Meritor Axle AXLE, REAR 52,000 Lb Meritor Axle	TRANSMISSION Allison 5th Gen, 4500 EVS P	PUMPHOUSE 48.00\" Compartment, No Pump PUMP Pump Not Required	CROSSLAYS, 1.50\" 1.50\" Crosslays Not Required CROSSLAYS, 2.50\" 2.50\" Crosslays Not Required	SPEEDLAYS Speedlays Not Required GENERATOR Generator Not Required	SAFETY Side Roll and Frontal Impact Protection
--	--	---	--	--	--	--	---

NOTE
 DIMENSIONS SHOWN ARE APPROXIMATE AND ARE SUBJECT TO MINOR DEVIATIONS AS MAY OCCUR OR BE NECESSARY IN CONSTRUCTION. MINOR DETAILS NOT SHOWN.

- DEF TANK MOUNTED UNDER CAB ON THE DRIVER'S SIDE
- AIR INLET WITH DISCONNECT COUPLING IN THE DRIVER SIDE STEPWELL
- SHORELINE RECEPTACLE WITH KISSMULL SUPER AUTO-EJECT LOCATED ON DRIVER SIDE OF THE CAB
- BATTERY CHARGER LOCATED IN CAB PER SHOP ORDER
- BATTERY CHARGER INDICATOR BEHIND DRIVER'S SEAT DISPLAYED THROUGH WINDOW
- FIVE ADJUSTABLE FULL WIDTH/FULL DEPTH SHELVES IN COMPARTMENTS PER SHOP ORDER
- ONE ADJUSTABLE 2-WAY SLIDE-OUT TRAY IN TRANSVERSE AREA PER SHOP ORDER
- FOUR FLOOR MOUNTED SLIDE-OUT TRAYS IN COMPARTMENTS PER SHOP ORDER
- ONE SWING-OUT TOOLBOARD IN COMPARTMENT PER SHOP ORDER
- ONE ADJUSTABLE TOOLBOARD MOUNTED ON A 2-WAY TRAY IN TRANSVERSE AREA PER SHOP ORDER
- 1.00\" RAISED AERIAL PEDESTAL
- LIFTING EYE ROPE RESCUE ATTACHMENT AT AERIAL TIP
- 1500 GPM HIGH FLOW WATERWAY
- 7.00\" AERIAL LIMITED RETRACTION
- STABILIZER COMPARTMENTS MODIFIED FOR 16\" SPREAD, 18\" GROUND PENETRATION

Pierce MANUFACTURING INC.

JOB NO. 35934
 SCALE 1:24
 DATE
 DRAWN BY TKA 04AUG21
 CHECKED BY ZCH 05AUG21
 SHEET SIZE D SHEET NO. 1 OF 1

TITLE 100' LSL AERIAL LADDER AND BODY ASSEMBLY
 FOR PIERCE FIELD UNIT APPLETON, WISCONSIN
 DWG NO. 35934AD

07APR22	LWE	NDA	CHASSIS DATA
17FEB22	LWE	NDA	MAKE
01FEB22	LWE	NDA	PIERCE
12NOV21	TKA	THS	MODEL
09AUG21	TKA	ZCH	ARROW XT
REV	DATE	BY	CH