

PUMPER BODY

Medium Aluminum 2nd Gen Pumper

CHASSIS

Velocity Chassis (Big Block)

CHASSIS AXLE, FRONT, CUSTOM
22,800 Lb TAK-4 Axle

AXLE, REAR
24,000 Lb Meritor Axle

ENGINE
510 HP W/OBD EPA 2021 Test Engine

TRANSMISSION
Allison 5th Gen, 4000 EVS P

BUMPER
19" Extended Painted Steel

CAB

7010 Velocity FR Cab

BODY WATER TANK

730 Gallon Poly Water Tank

COMPT, PUMPER, REAR
37.75" FF RollUp Rear Compt

COMPT, PUMPER, DRIVER SIDE
152" RollUp Full Height Front & Rear FDLR

COMPT, PUMPER PASS. SIDE
152" RollUp Full Height Front & Rear FDLR

FIRE SUPPRESSION PUMPHOUSE

52" Control Zone Side Mount

PUMP

2000 GPM Waterous CSU

CROSSLAYS, 1.50"
(2) 1.50" Standard Capacity

CROSSLAYS, 2.50"
(1) 2.50" Standard Capacity

SPEEDLAYS

Speedlays Not Required

GENERATOR

Generator Not Required

Foam System

Husky 3 Single Agent Foam System

Foam Cell

20 Gallon Foam Cell, Reduced Water

Side Roll and Frontal Impact Protection

NOTE
DIMENSIONS SHOWN ARE APPROXIMATE AND ARE SUBJECT TO MINOR DEVIATIONS AS MAY OCCUR OR BE NECESSARY IN CONSTRUCTION. MINOR DETAILS NOT SHOWN.

- ONE 1.50" OUTLET WITH 2.00" PIPING AND SWIVEL LOCATED IN CENTER BUMPER TRAY
- SHORELINE RECEPTACLE WITH KUSSMAUL SUPER AUTO-EJECT LOCATED ON DRIVER SIDE OF THE CAB
- AIR INLET WITH DISCONNECT COUPLING RECESSED IN THE DRIVER SIDE STEPMILL
- BATTERY CHARGER LOCATED IN CAB SEAT BOX
- BATTERY CHARGE INDICATOR LOCATED ON THE DRIVER SIDE SEAT RISER
- SEVEN ADJUSTABLE SHELVES IN COMPARTMENTS PER SHOP ORDER
- GOUT FLOOR MOUNTED SLIDE-OUT TRAYS IN COMPARTMENTS PER SHOP ORDER

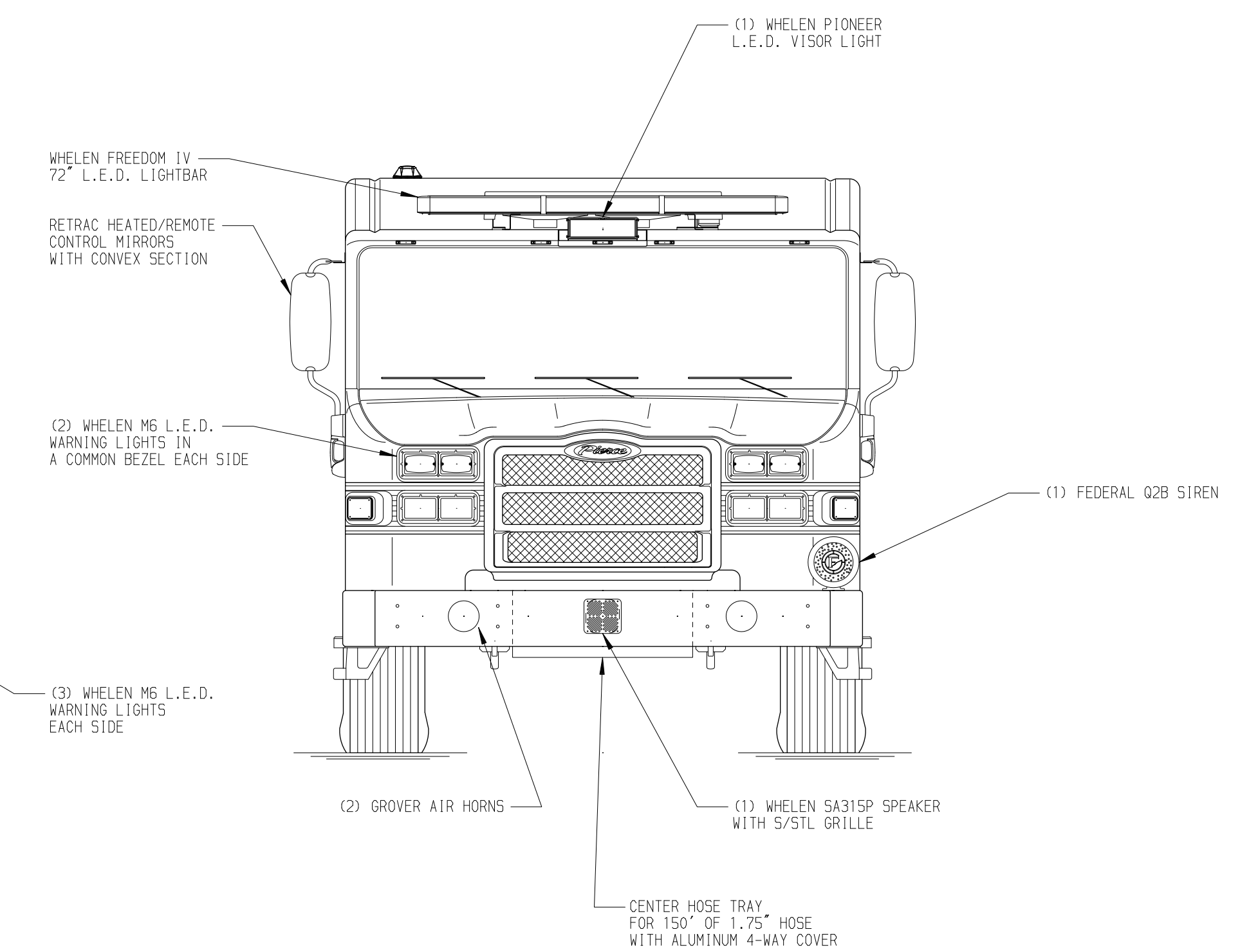
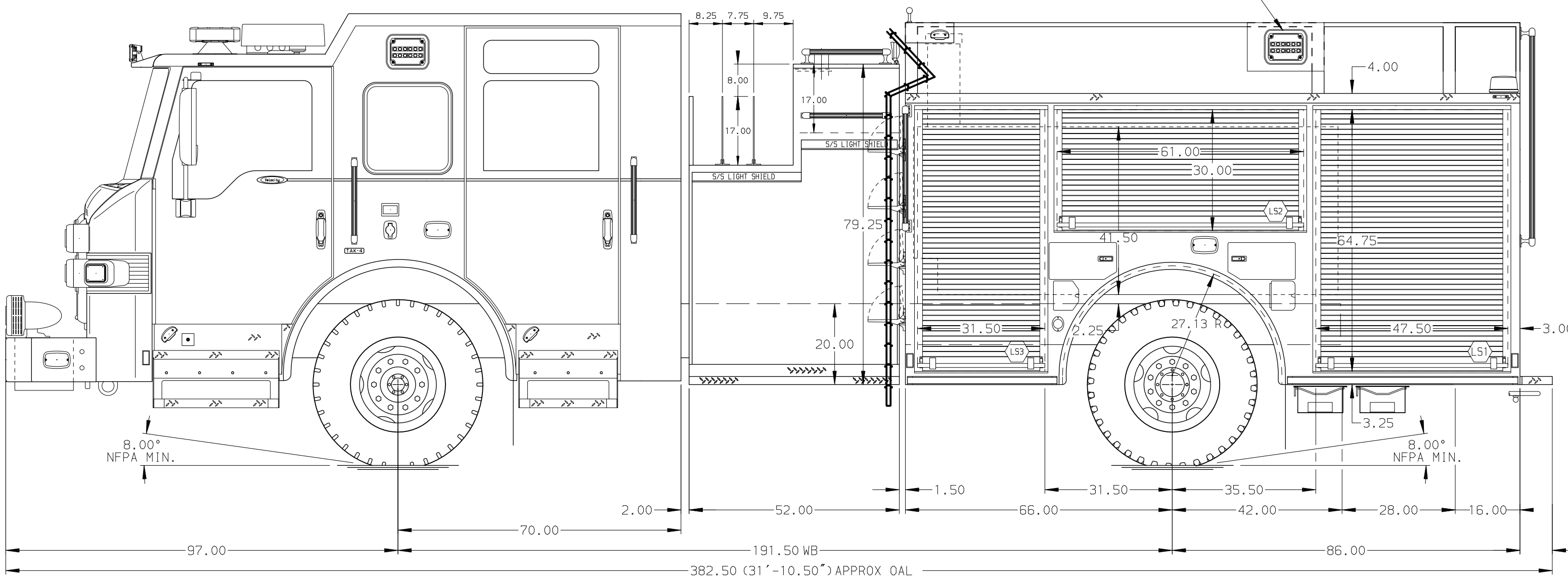
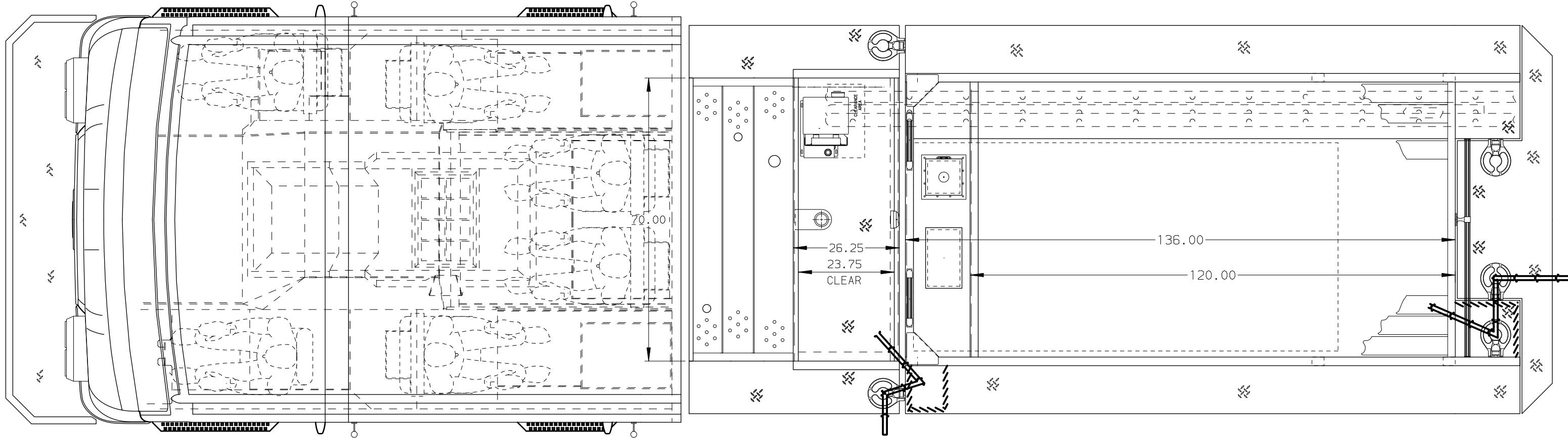
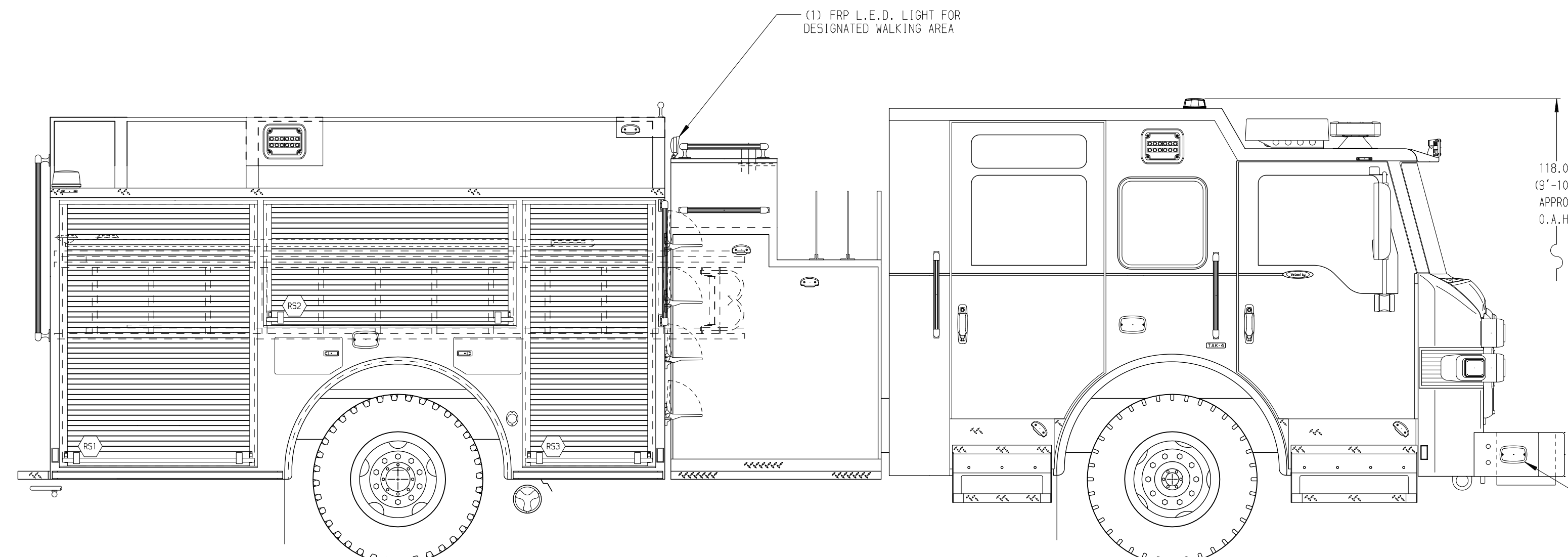

HOSEBED CAPACITY	
BED 1	500' OF 3.00" D.J. POLY HOSE
BED 2	1000' OF 5.00" D.J. POLY HOSE
BED 3	500' OF 3.00" D.J. POLY HOSE

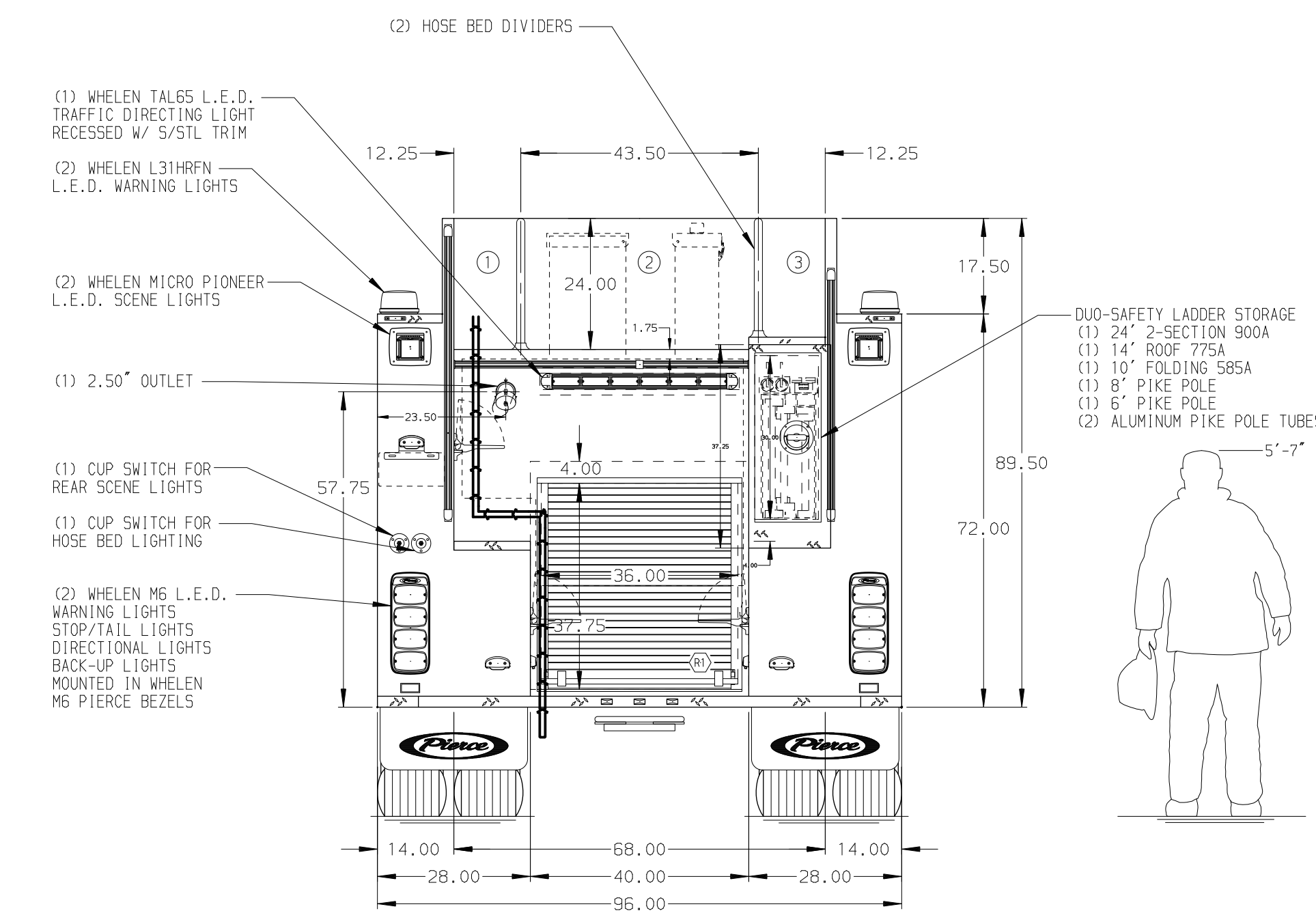

CUSTOMER APPROVAL			
APPROVED BY: _____			
DATE: _____			
03JUN20	MMF	THS	PIERCE
31MAR20	MMF	NPE	MODEL
REV	DATE	BY	CH VELOCITY

Pierce MANUFACTURING INC.		JOB NO.	34964
Pierce Pumper Approval Drawing		SCALE	1:24 DATE
Pierce Stock Unit		DRAWN BY	MMF 18MAR20
DWG NO. 34964AD		CHECKED BY	NPE 25MAR20
		SHEET SIZE	D SHEET NO. 1 OF 1