

BODY 107' ASL Aluminum Body COMPT, LEFT SIDE FRONT Full Height RollUp Forward COMPT, LEFT SIDE REAR Full Height RollUp Rearward COMPT, RIGHT SIDE FRONT Full Height RollUp Forward COMPT, RIGHT SIDE REAR Full Height RollUp Rearward	WATER TANK 500 Gallon Poly Water Tank Foam System Plumbing for Future Husky Foam System Foam Cell 20 Gallon Foam Cell, Non Reduced Water
---	--

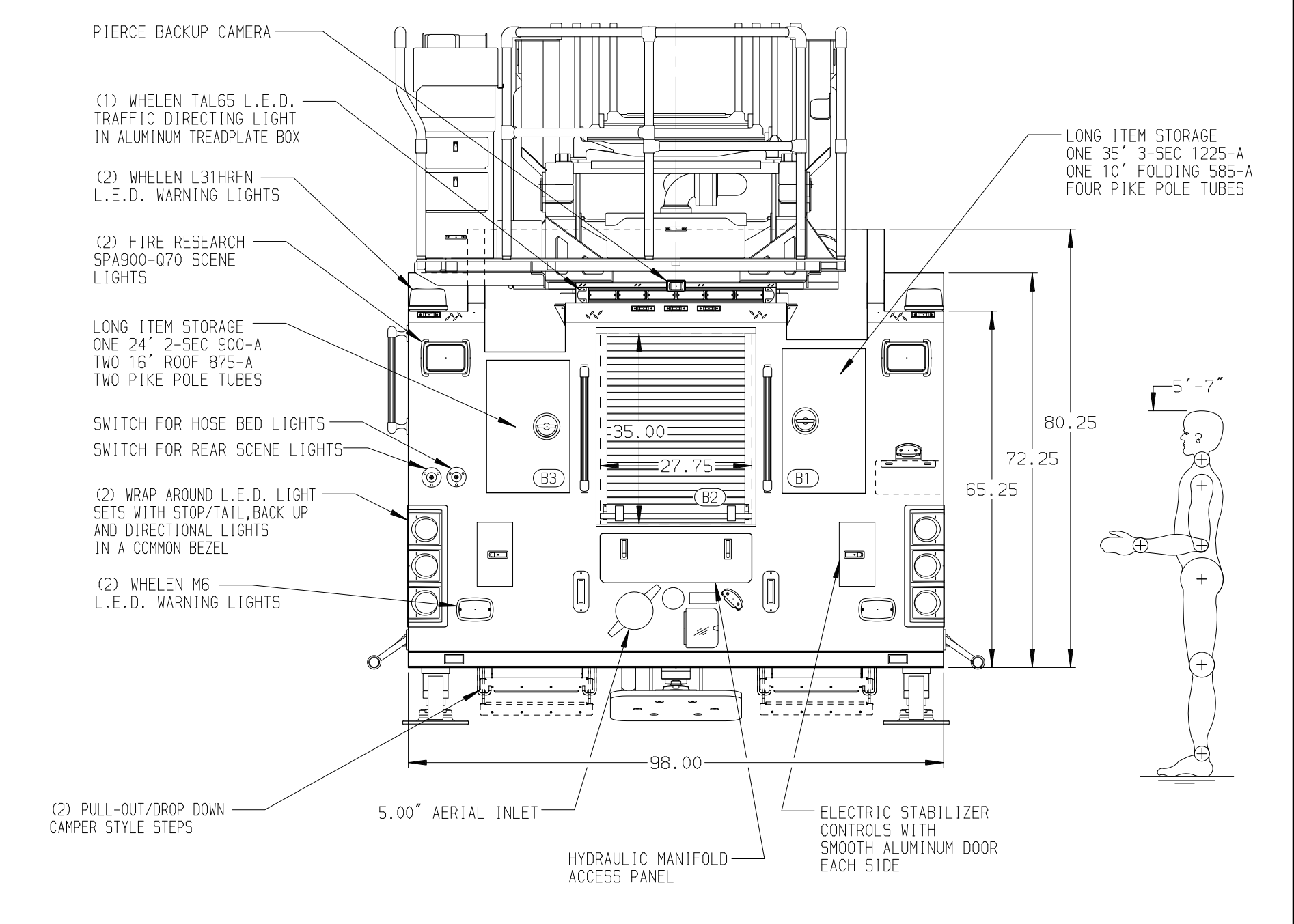
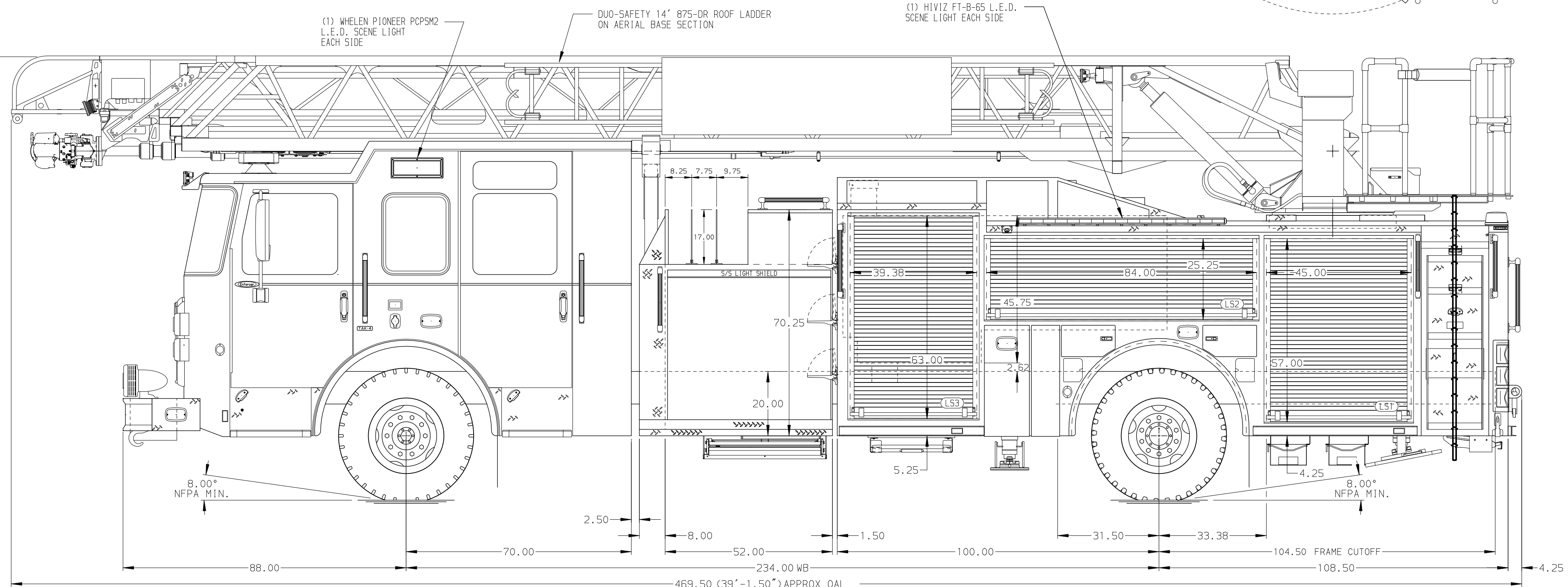

CHASSIS Enforcer Chassis ENGINE 500 HP Cummins X12 Engine	CAB 7010 Enforcer Notched Cab BUMPER 19\" Extended Stainless Steel	AXLE, FRONT, CUSTOM 22,800 Lb TAK-4 Axle AXLE, REAR 33,500 Lb Meritor Axle	TRANSMISSION Allison 5th Gen, 4500 EVS P	PUMPHOUSE 52\" Control Zone Side Mount PUMP 2000 GPM Waterous CSU	CROSSLAYS, 1.50\" (2) 1.50\" Standard Capacity CROSSLAYS, 2.50\" (1) 2.50\" Standard Capacity	SPEEDLAYS Speedlays Not Required GENERATOR Generator Not Required	SAFETY Side Roll and Frontal Impact Protection	CUSTOMER APPROVAL APPROVED BY: _____ DATE: _____		JOB NO. 35898 SCALE 1:24 DATE DRAWN BY LWE 01DEC20 CHECKED BY THS 3DEC20 SHEET SIZE D SHEET NO. 1 OF 1
NOTE DIMENSIONS SHOWN ARE APPROXIMATE AND ARE SUBJECT TO MINOR DEVIATIONS AS MAY OCCUR OR BE NECESSARY IN CONSTRUCTION. MINOR DETAILS NOT SHOWN.										
1. ONE 1.50\" OUTLET WITH 2.00\" PIPING AND SWIVEL LOCATED IN CENTER BUMPER TRAY 2. SHOVELLINE RECEPTACLE WITH KUSSMAUL SUPER AUTO-EJECT LOCATED ON DRIVER SIDE OF THE CAB 3. AIR INLET WITH DISCONNECT COUPLING IN THE DRIVER SIDE STEPWELL 4. BATTERY CHARGER LOCATED BEHIND DRIVER SEAT 5. BATTERY CHARGE INDICATOR LOCATED ON DRIVERS SIDE CAB 6. DUAL L.E.D. LIGHT STRIPS LOCATED IN HOSE BED 7. SIX ADJUSTABLE SHELVES LOCATED IN COMPARTMENTS PER SHOP ORDER 8. FOUR FLOOR MOUNTED SLIDE-OUT TRAYS LOCATED IN COMPARTMENTS PER SHOP ORDER 9. NON-RAISED AERIAL PEDESTAL 10. 1500 GPM HIGH FLOW WATERWAY 11. LIMITED RETRACTION NOT REQUIRED 12. MOUNTING PROVISIONS FOR FRONT INLET 13. RUNG LIGHTING ON AERIAL LADDER										