

BODY 100' Ascendant Aerial Tower No Pump Alum Body	WATER TANK Water Tank Not Required
COMPT, LEFT SIDE Full Height Lap Doors	Foam System Foam System Not Required
COMPT, RIGHT SIDE Full Height Lap Doors	Foam Cell Foam Cell Not Required

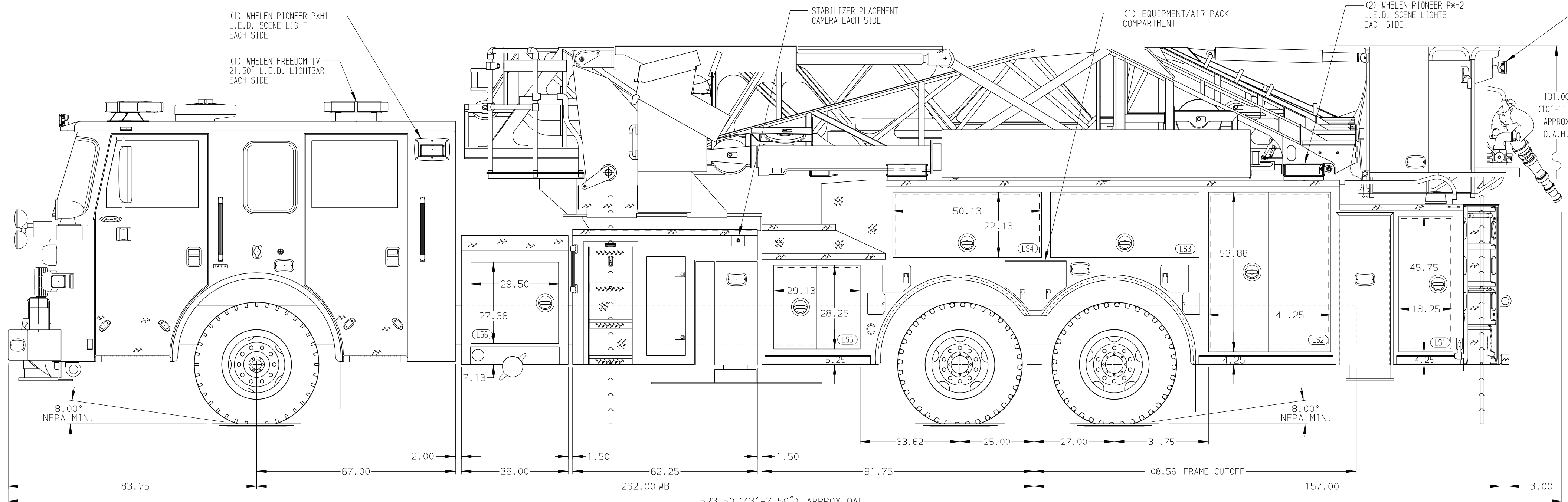
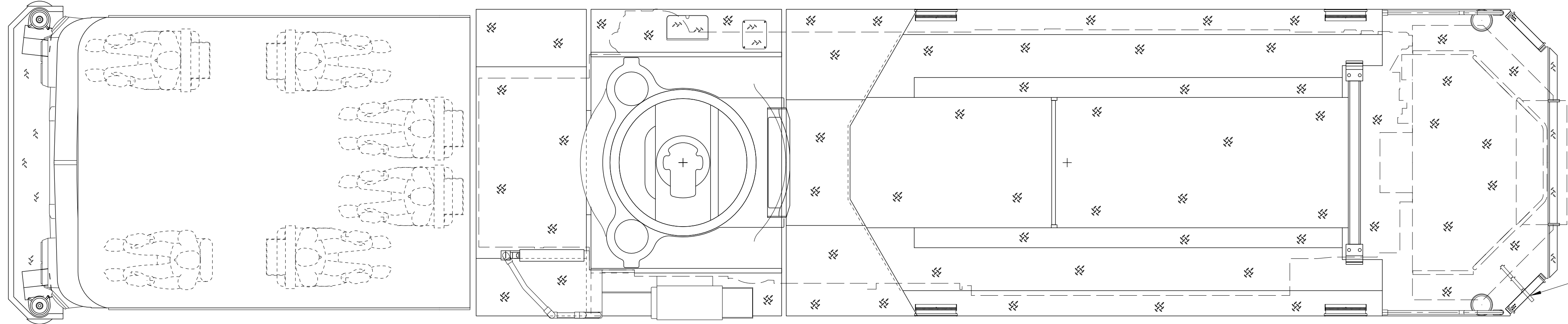

CHASSIS Arrow XT Chassis 605 HP Cummins X15 Engine	CAB 6700 Arrow XT Cab 15" Extended Painted Aluminum	AXLE, FRONT, CUSTOM 24,000 Lb TAK-4 Axle AXLE, REAR 48,000 Lb Meritor Axle	TRANSMISSION Allison 5th Gen, 4000 EV5 P	PUMPHOUSE 36" Compartment, No Pump, Lap Door PUMP No Pump Required	CROSSLAYS, 1.50" 1.50" Crosslays Not Required CROSSLAYS, 2.50" 2.50" Crosslays Not Required	SPEEDLAYS Speedlays Not Required GENERATOR Generator Not Required
NOTE DIMENSIONS SHOWN ARE APPROXIMATE AND ARE SUBJECT TO MINOR DEVIATIONS AS MAY OCCUR OR BE NECESSARY IN CONSTRUCTION. MINOR DETAILS NOT SHOWN.						
1. SHORELINE RECEPTACLE WITH KUSSMAUL SUPER AUTO-EJECT LOCATED ON DRIVER SIDE OF THE CAB 2. AIR INLET WITH DISCONNECT FITTING AND KUSSMAUL AUTO-EJECT LOCATED ON DRIVER SIDE OF THE CAB 3. BATTERY CHARGER MOUNTED BEHIND PASSENGER'S SIDE SEAT 4. BATTERY CHARGE INDICATOR LOCATED NEAR DRIVER SEAT RISER WITH BRACKET 5. SEVEN ADJUSTABLE FULL WIDTH/FULL DEPTH SHELVES IN COMPARTMENTS PER SHOP ORDER 6. TWO FLOOR EXTENSIONS IN COMPARTMENTS PER SHOP ORDER 7. TWO 120V DUPLEX RECEPTACLES IN COMPARTMENTS PER SHOP ORDER 8. DC POWER TO AERIAL BASKET 9. NON-RAISED AERIAL PEDESTAL			10. 3-in-1 LYFECOMBO BRACKETS AT AERIAL BASKET 11. AIR HORN CONTROL AT AERIAL TURNTABLE 12. LIMITED RETRACTION NOT REQUIRED		MAX. OAH = 131.00" (10'-11") MAX. OAL = 524.00" (43'-8") MAX. OAW = 102.00" (8'-6") MAXIMUM G.V.W. = 72,000# MIN. ANGLE OF APPROACH (LOADED) 8° MIN. ANGLE OF DEPARTURE (LOADED) 8°	

Pierce MANUFACTURING INC.		JOB NO.	36183
		SCALE	1:24
		DATE	28APR21
TITLE		DRAWN BY	TKA
FOR		CHECKED BY	CRI
DWG NO.		SHEET SIZE	D
36183AD		SHEET NO.	1 OF 1