

HOSEBED CAPACITIES  
 ① 200' OF 2.50" D.J. POLYESTER HOSE

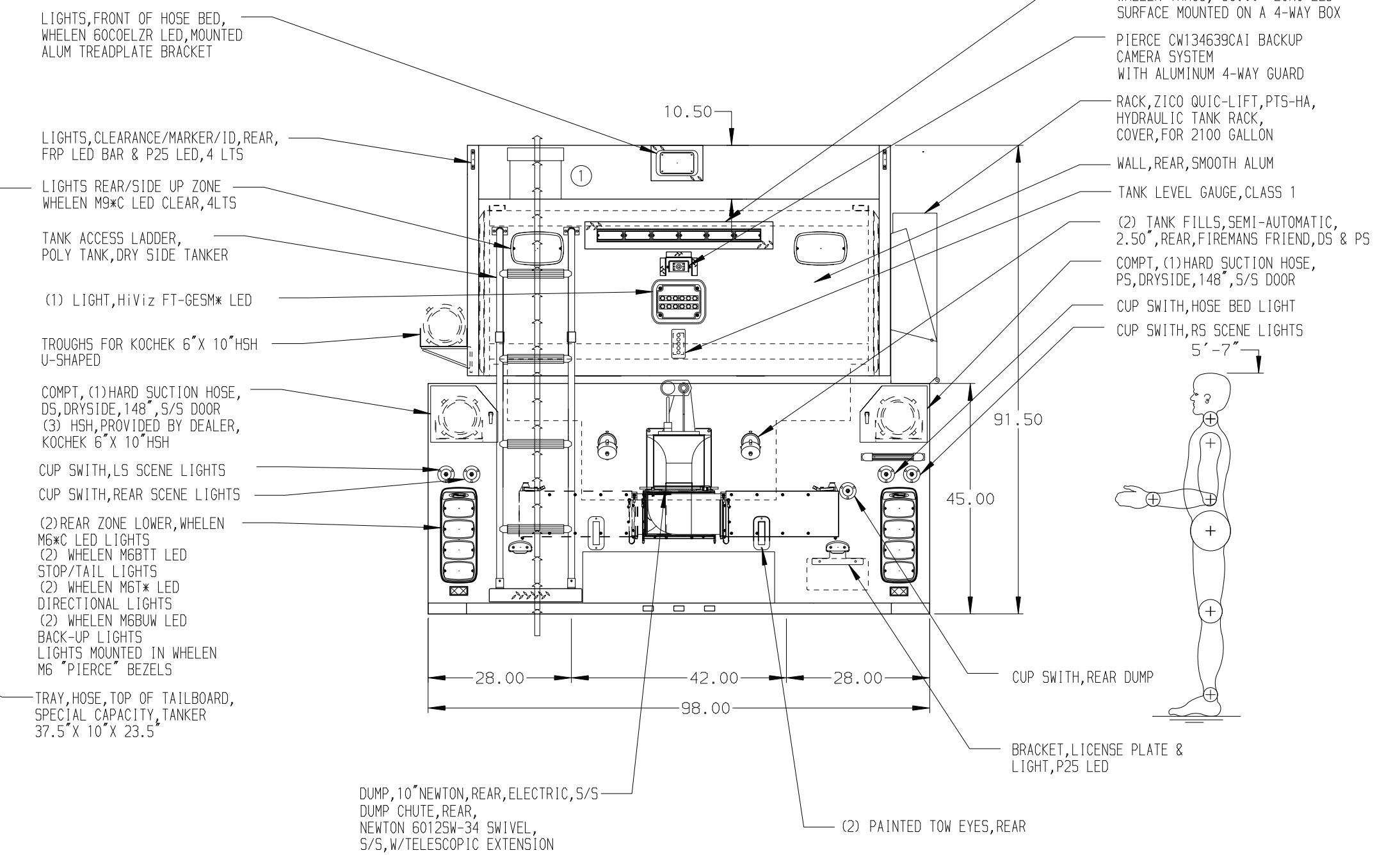
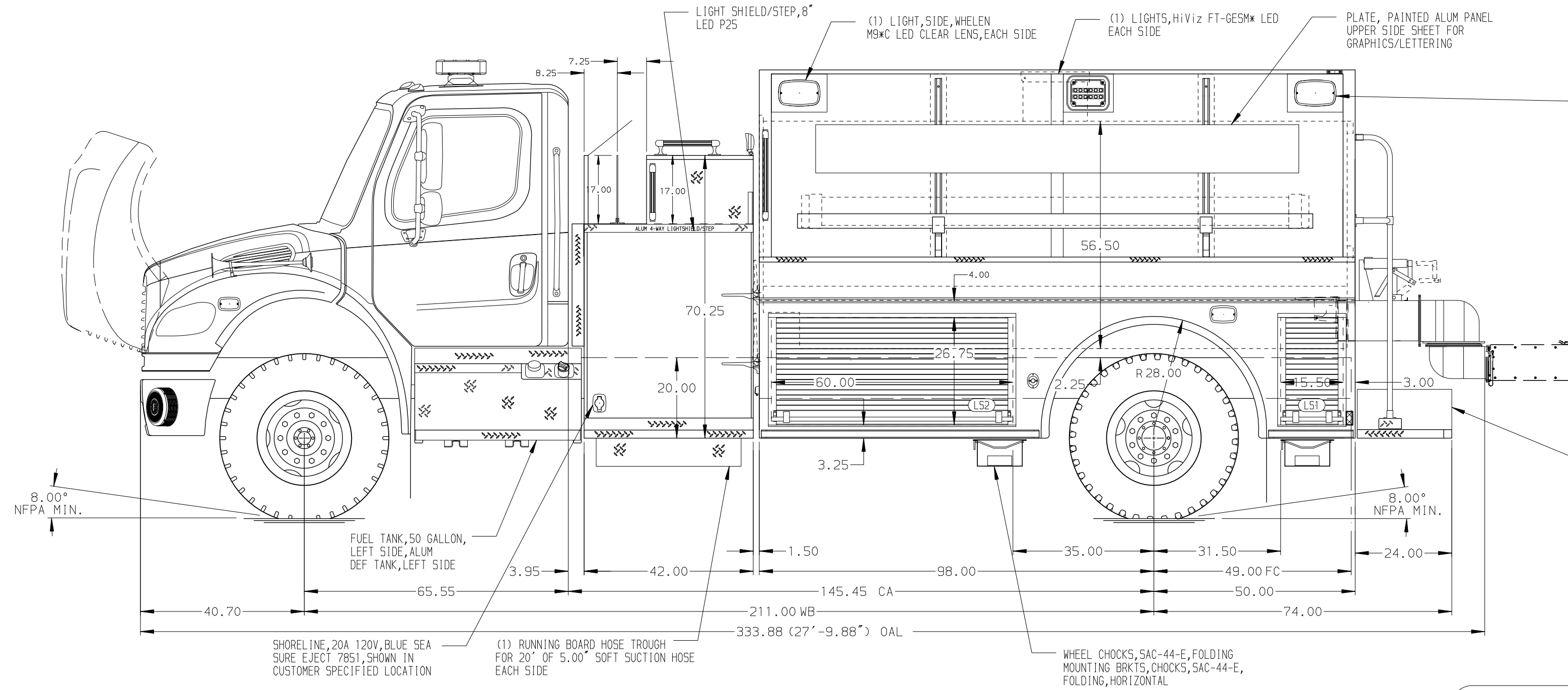

ALUMINUM BODY

SIDE ROLL PROTECTION

NOTE  
 DIMENSIONS SHOWN ARE APPROXIMATE AND ARE SUBJECT TO MINOR DEVIATIONS AS MAY OCCUR OR BE NECESSARY IN CONSTRUCTION. MINOR DETAILS NOT SHOWN.

REV	DATE	BY	CH	CHASSIS DATA
23SEP21	JLA	GSC		MAKE
02SEP21	JLA	GSC		FL
09JUN21	JLA	RW1		MODEL
				M2-106

<p>MANUFACTURING INC. BRADENTON, FLORIDA</p>		JOB NO.	36213
		SCALE	DATE
TITLE	750-D-2000 POLY, 148" DRYSIDE 42" SIDE CONTROL, (2) 1.5" CROSSLAYS	DRAWN BY	JLA
FOR	WAKE COUNTY NC RALEIGH, NORTH CAROLINA	CHECKED BY	RWI
DWG NO.	36213AD	SHEET SIZE	D
		SHEET NO.	1 OF 1