

- RIGHT SIDE COMPARTMENTS CONTAIN THE FOLLOWING:**
- COMPARTMENT R51 CONTAINS:
 - (1) STD DEPTH ADJ SHELF
 - (1) HORIZONTAL FLOOR EXTENSION
 - (1) STD DEPTH FLOOR MOUNTED TRAY WITH TOOLBOARD
 - (1) RACK FOR 4 AIR BAGS
 - ALUMINUM TREADPLATE ON FLOOR
 - COMPARTMENT R52 CONTAINS:
 - (1) RACK FOR 12 SCBA BOTTLES
 - (1) STD DEPTH ADJ SHELF
 - (1) VERTICAL COMPARTMENT DIVIDER
 - COMPARTMENT R53 CONTAINS:
 - (2) SWING OUT TOOLBOARDS
 - COMPARTMENT R54 CONTAINS:
 - (1) HORIZONTAL FLOOR EXTENSION
 - (1) 1/2 DEPTH FLOOR MTD SLIDE OUT TRAY
 - (1) 1/2 DEPTH ADJ SLIDE OUT/TILT TRAY
 - COMPARTMENT R55 CONTAINS:
 - (1) CAB LIFT CONTROLLER
 - (2) STD DEPTH ADJ SHELVES
 - ALUMINUM TREADPLATE ON FLOOR

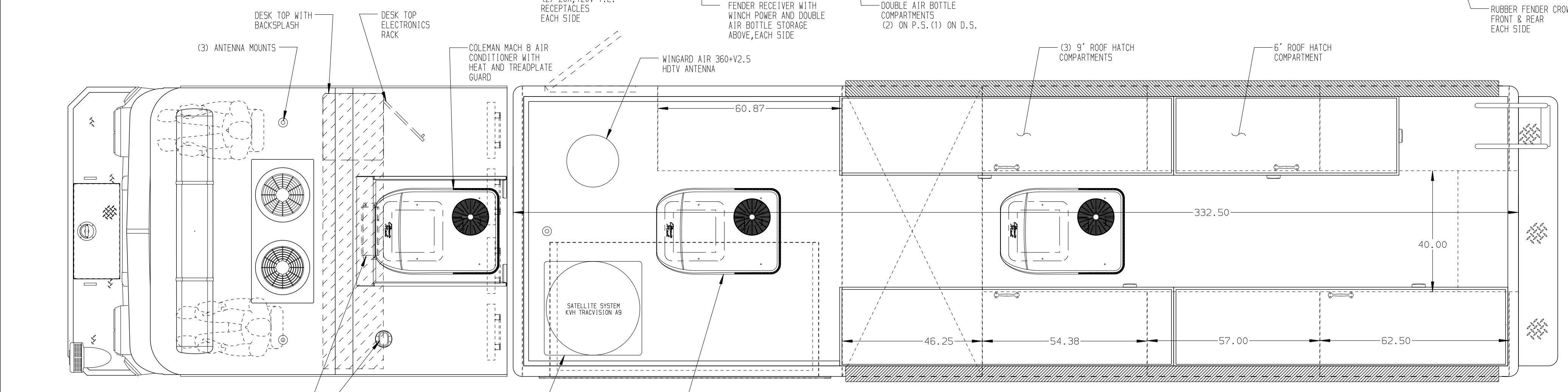

- LEFT SIDE COMPARTMENTS CONTAIN THE FOLLOWING:**
- COMPARTMENT L51 CONTAINS:
 - (1) VERTICAL COMPARTMENT DIVIDER
 - (2) STD DEPTH ADJ SHELVES
 - ALUMINUM TREADPLATE ON FLOOR
 - COMPARTMENT L52 CONTAINS:
 - (1) STD DEPTH ADJ SHELF
 - COMPARTMENT L53 CONTAINS:
 - (1) STD DEPTH ADJ SHELF
 - COMPARTMENT L54 CONTAINS:
 - (1) HORIZONTAL FLOOR EXTENSION
 - (1) 1/2 DEPTH FLOOR MTD SLIDE OUT TRAY
 - ALUMINUM TREADPLATE ON FLOOR
 - 6 GALLON DEF FLUID TANK
 - COMPARTMENT L55 CONTAINS:
 - COMPARTMENT L56 CONTAINS:
 - (1) KUSSMAUL PUMP PLUS 1200 CHARGER

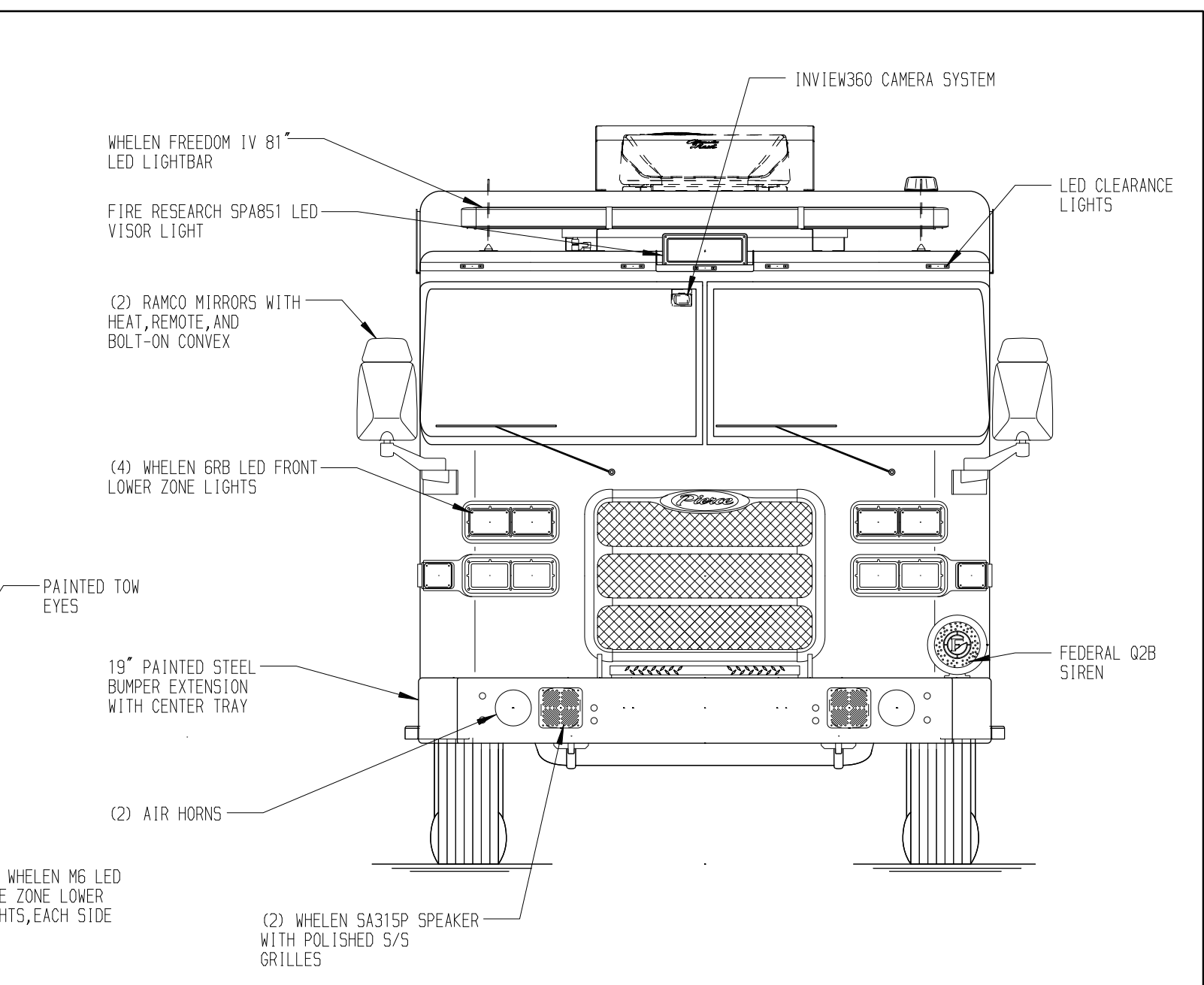
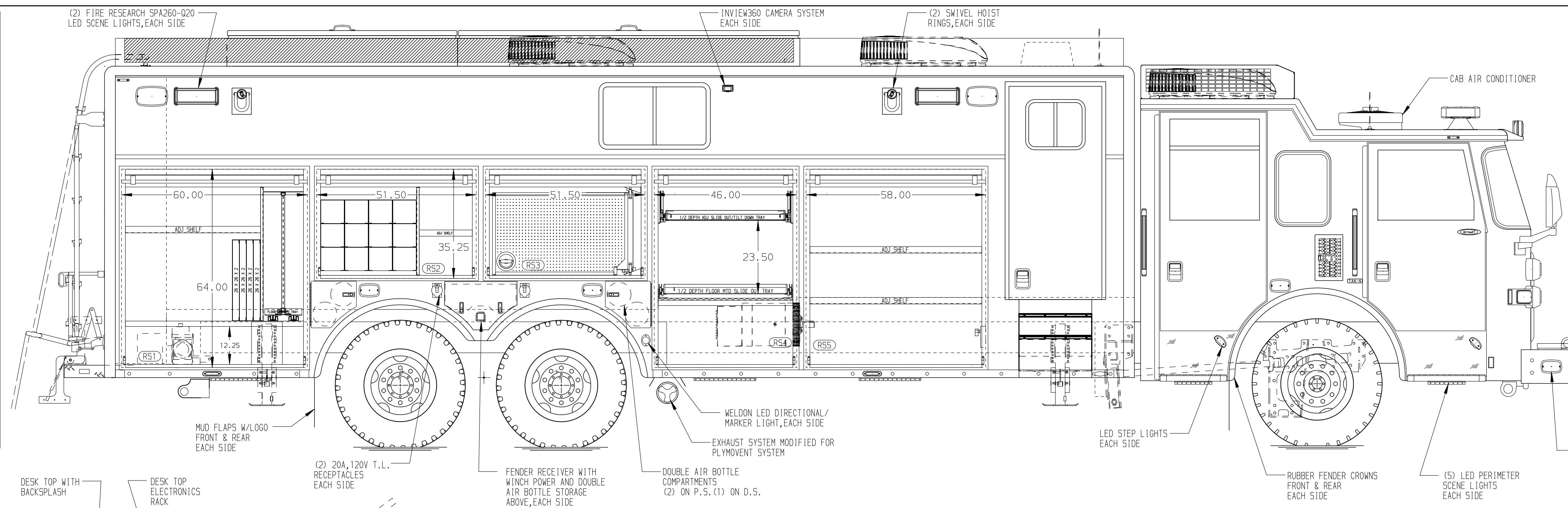
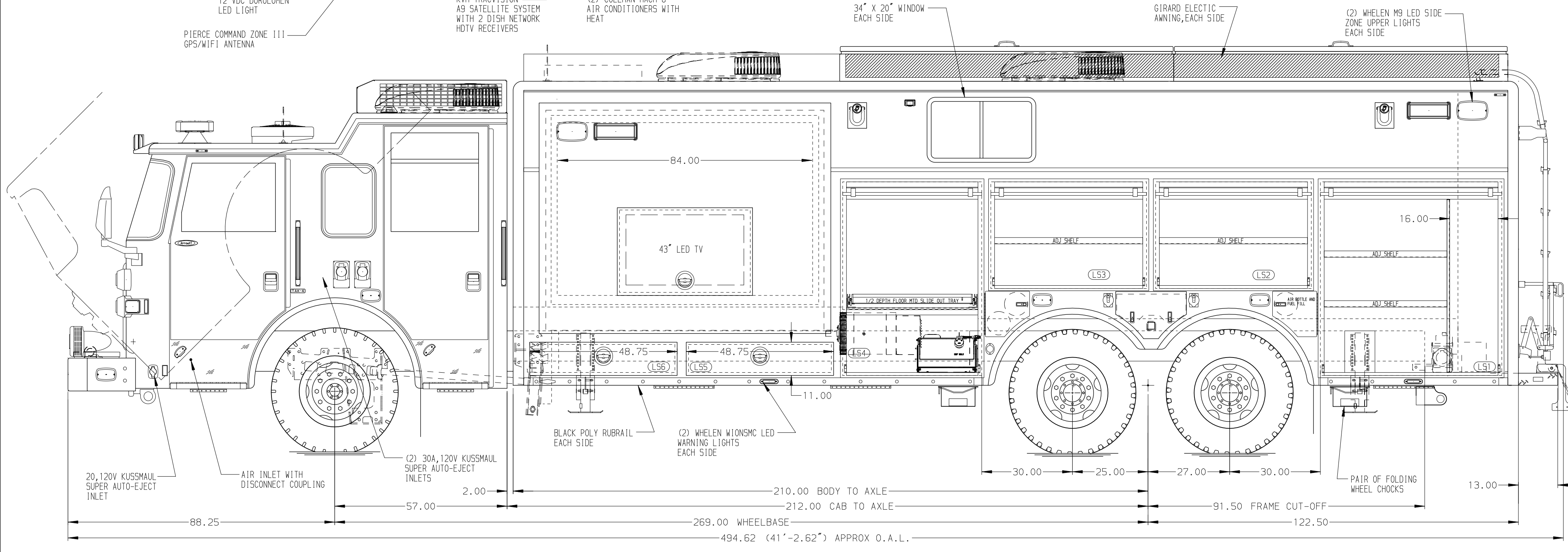
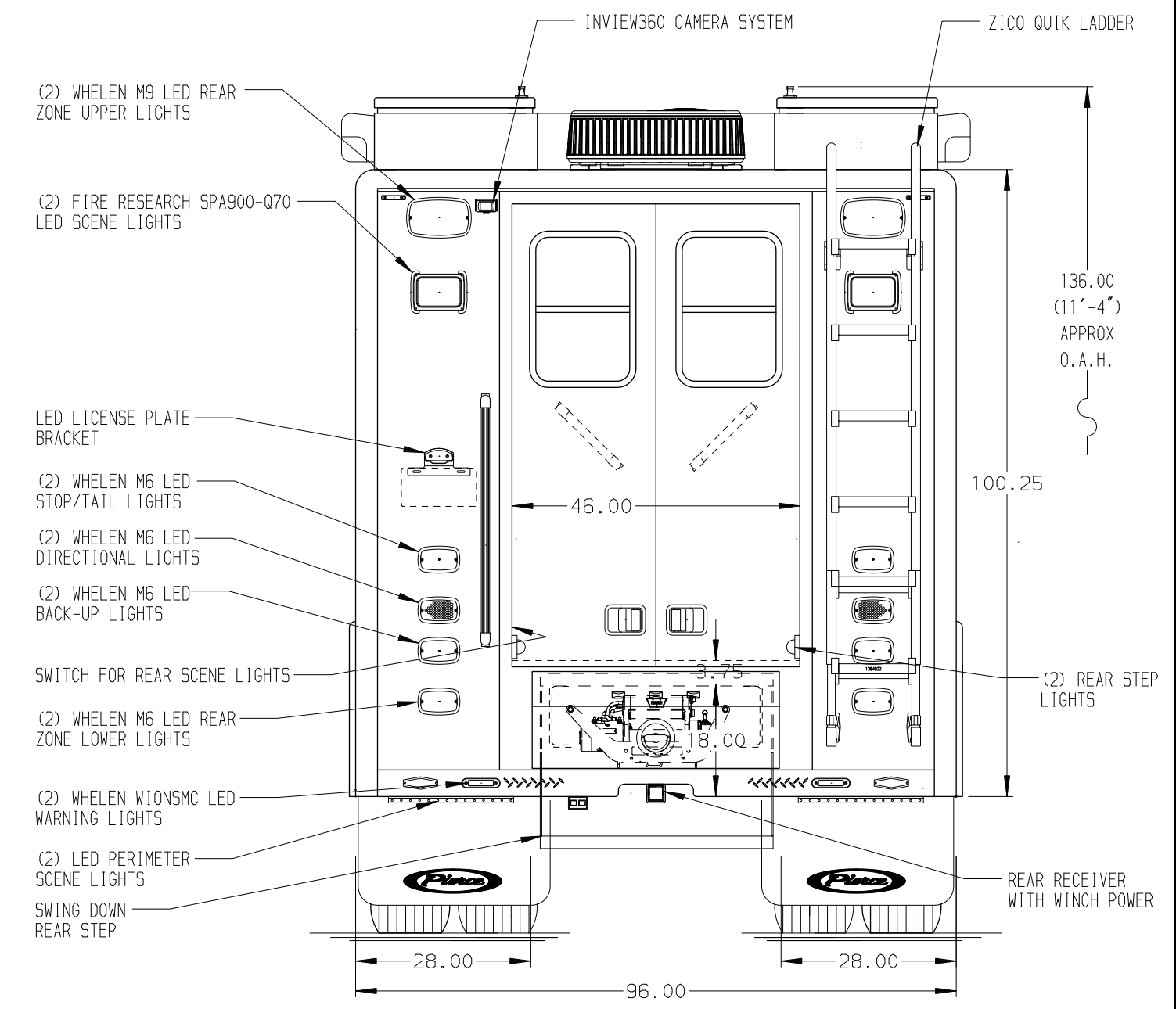

NOTE
DIMENSIONS SHOWN ARE APPROXIMATE AND ARE SUBJECT TO MINOR DEVIATIONS AS MAY OCCUR OR BE NECESSARY IN CONSTRUCTION. MINOR DETAILS NOT SHOWN.

- NOTES:**
- WARN #9,000 PORTABLE RECEIVER STYLE WINCH
 - FLOOR IN CAB AND CREW CAB TO BE PADDED RUBBER
 - ONAN 25KW SINGLE PHASE PTO DRIVEN GENERATOR LOCATED BETWEEN THE FRAME RAILS
 - BATTERY CHARGE INDICATOR LOCATED ON DRIVER'S SEAT RISER
 - 816 FOOT AUTOMATIC LEVELING SYSTEM
 - 5/5 GUARDS ON ALL BODY ROLL-UP DOORS
 - PULL STRAPS ON ALL BODY ROLL-UP DOORS
 - PIERCE LED LIGHTS IN ALL BODY COMPARTMENTS
 - POLISHED 5/5 SCUFFPLATES ON CAB AND CREW CAB DOOR JAMBS

(SIDE ROLL & FRONTAL IMPACT PROTECTION)

CLEAR DOOR WIDTH KEY		CHASSIS DATA	TITLE
AMOR ROLL UP DOORS:	-2 1/4"	05JAN22	DHE AZU MAKE
CORTITE ROLL UP DOORS:	-2 1/2"	07OCT21	DHE AZU PIERCE
PIERCE DOUBLE LIP DOORS:	-4 1/4"	26JUL21	DHE AZU MODEL
PIERCE LIFT-UP LAP DOORS:	-1 1/2"		REV DATE BY CH
(EX: 60" F-F - 2 1/4" = 57 3/4" CLEAR)			AX5710
(F-F) = FRAME TO FRAME			

Pierce MANUFACTURING INC.

JOB NO. 36402

SCALE 1:24 DATE

TITLE HEAVY DUTY RESCUE WALKIN/NON-WALKIN COMBO

FOR GRAND PRAIRIE FIRE DEPARTMENT

BID #792 TRAVIS OWNBY

DWG NO. 36402AD-SH1

DRAWN BY DHE 13JUL21

CHECKED BY AZU 15JUL21

SHEET SIZE D SHEET NO. 1 OF 1