

- HOSEBED CAPACITIES**
- ① 700' OF 3.00" D.J. POLY HOSE
 - ② 700' OF 3.00" D.J. POLY HOSE
 - ③ 250' OF 1.75" D.J. POLY HOSE
 - ④ 250' OF 1.75" D.J. POLY HOSE

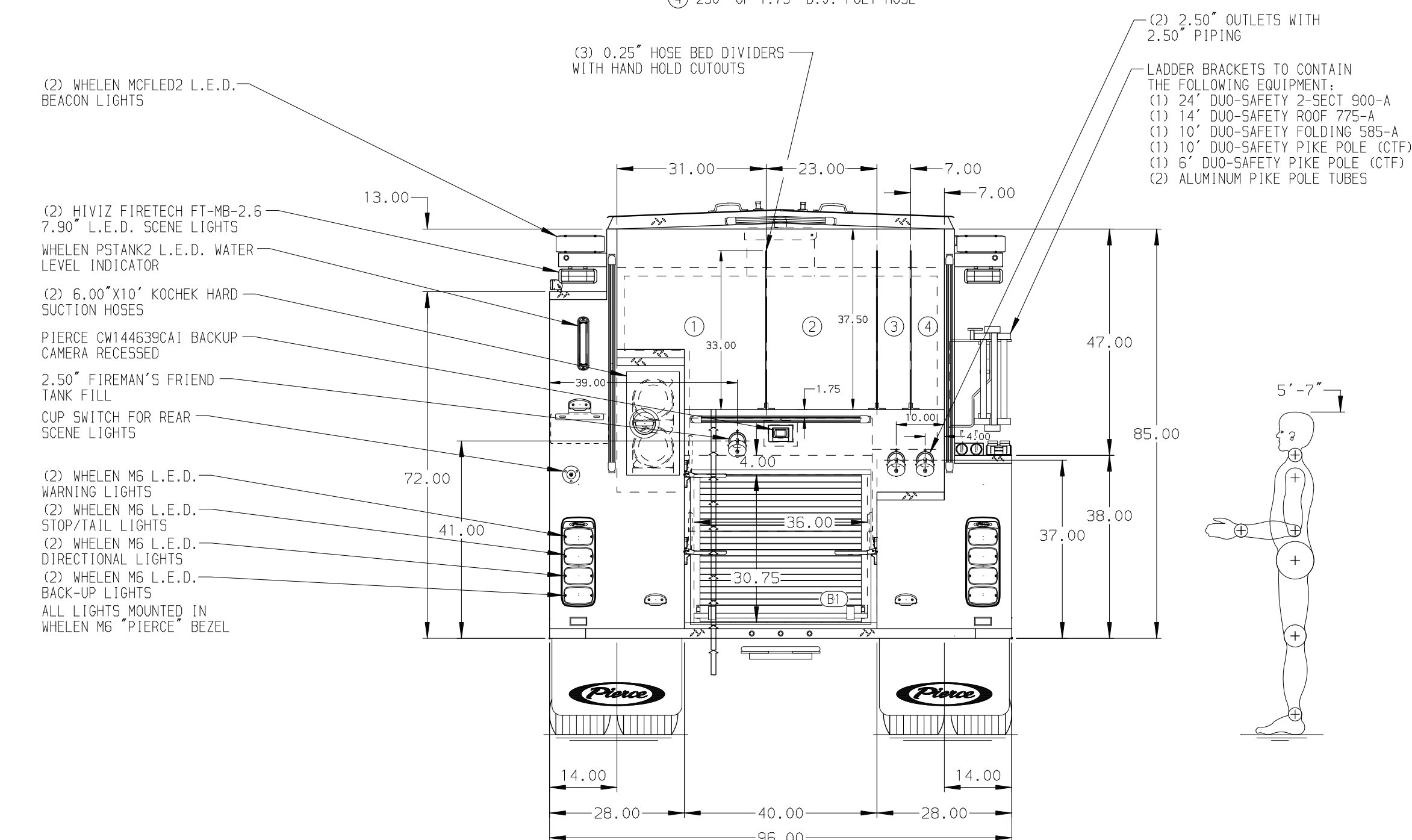
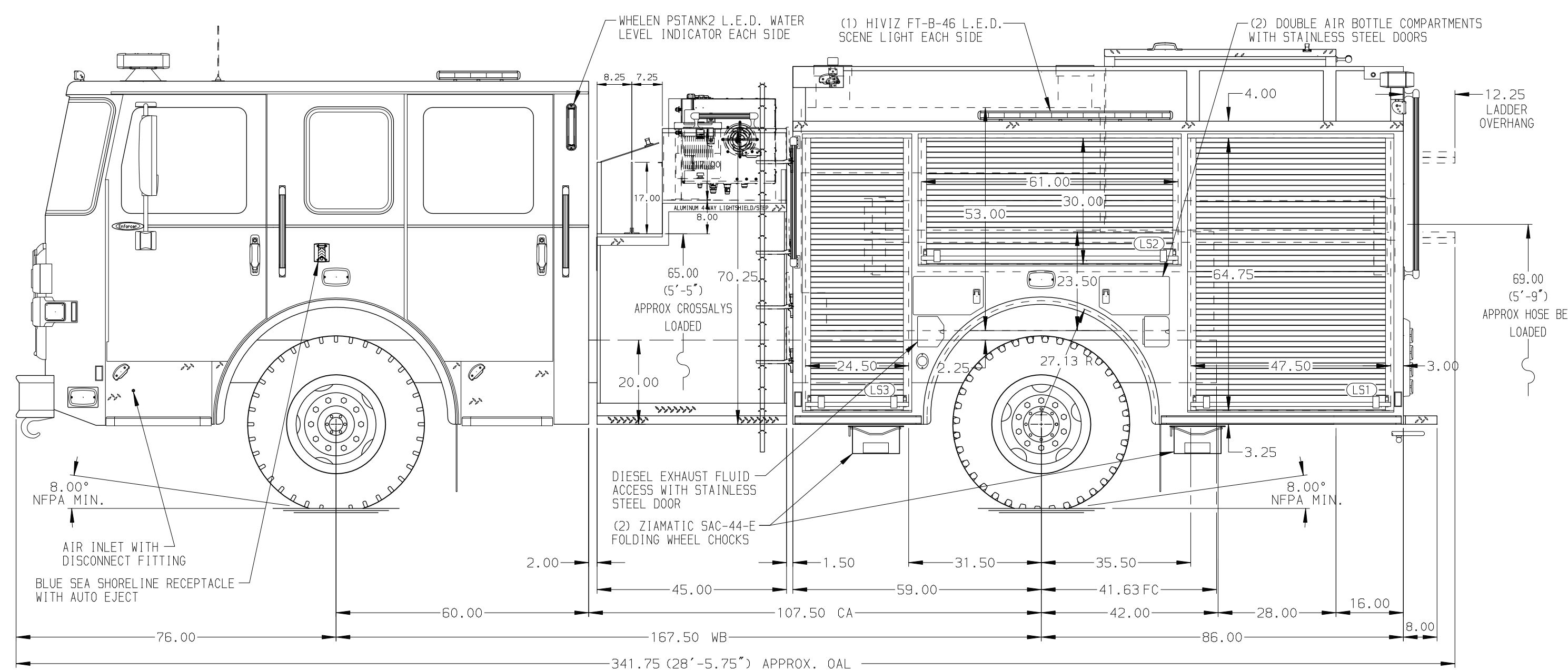

ALUMINUM BODY SIDE ROLL AND FRONTAL IMPACT PROTECTION

NOTE
DIMENSIONS SHOWN ARE APPROXIMATE AND ARE SUBJECT TO MINOR DEVIATIONS AS MAY OCCUR OR BE NECESSARY IN CONSTRUCTION. MINOR DETAILS NOT SHOWN.

1. ONSPOUT AUTOMATIC TIRE CHAINS TO BE PROVIDED AT REAR
2. BATTERY CHARGER LOCATED PER OPTION LIST
3. BATTERY CHARGER INDICATOR LOCATED PER OPTION LIST
4. L.E.D. LIGHT STRIPS WALKING SURFACE LIGHTING LOCATED PER OPTION LIST
5. FOUR FULL WIDTH/DEPTH ADJUSTABLE SHELVES WITH SIDES LOCATED PER OPTION LIST
6. ONE FLOOR MOUNTED SLIDE-OUT TRAY WITH SIDES LOCATED PER OPTION LIST
7. ONE SWING-OUT TOOLBOARD WITH PEGBOARD PATTERN LOCATED PER OPTION LIST
8. PAC TRAC EQUIPMENT MOUNTING SYSTEM ON THE REAR WALL LOCATED PER OPTION LIST

		JOB NO.	36415
		SCALE	DATE
TITLE 1250-D-775P, 750 GAL. WATER W/25 GAL. FOAM CELL 145" PUMPER BODY, LS FH FDLR, RS LOW, 45" SIDE CONTROL		DRAWN BY	20JUL21
FOR FLOYD COUNTY FIRE DEPARTMENT MANASSAS, VA		CHECKED BY	20JUL21
DWG NO. 36415AD		SHEET SIZE	SHEET NO.
		D	1 OF 1

22DEC21	BST	DTJ	CHASSIS DATA
22OCT21	JRO	CSH	MAKE
05AUG21	CDU	CZA	PIERCE
REV	DATE	BY	CH