

133.00
(11'-1")
APPROX
O.A.H.

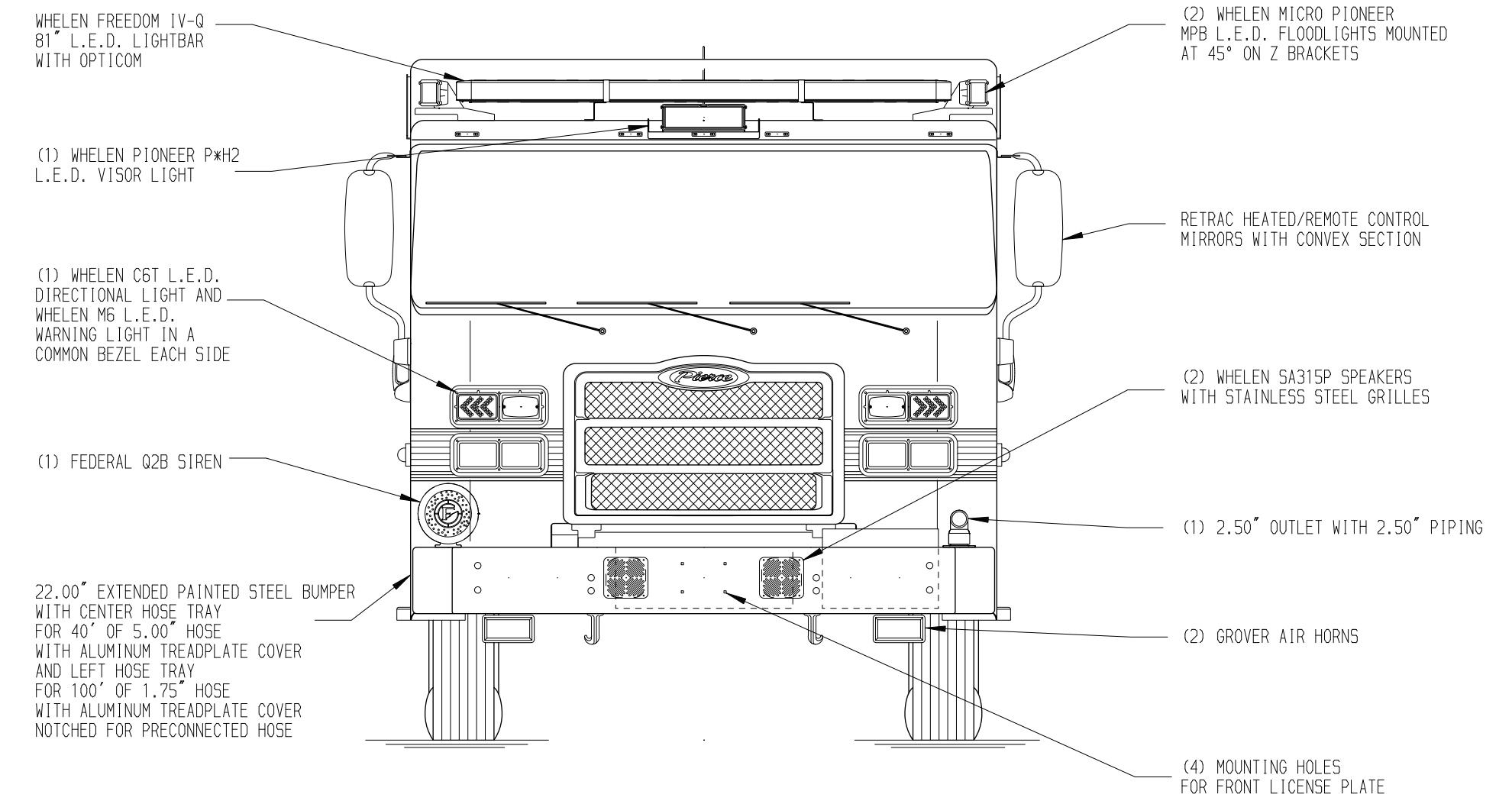
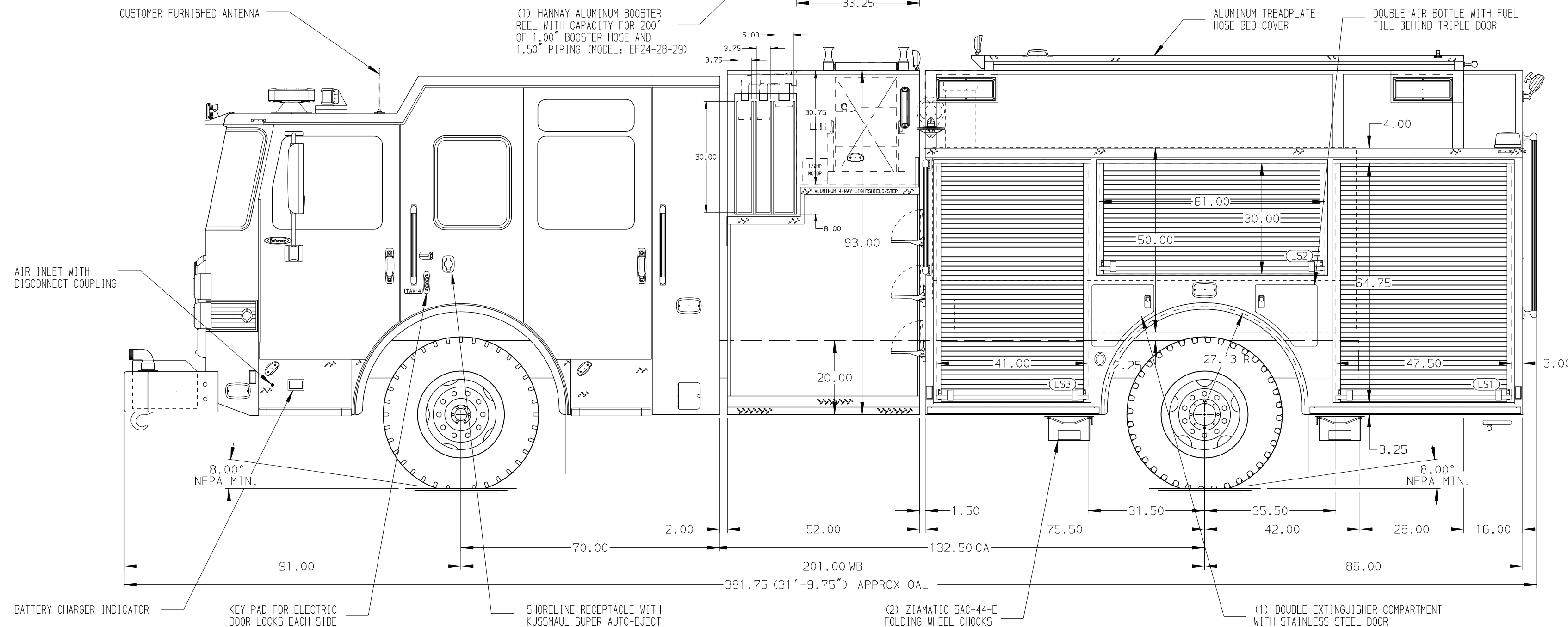
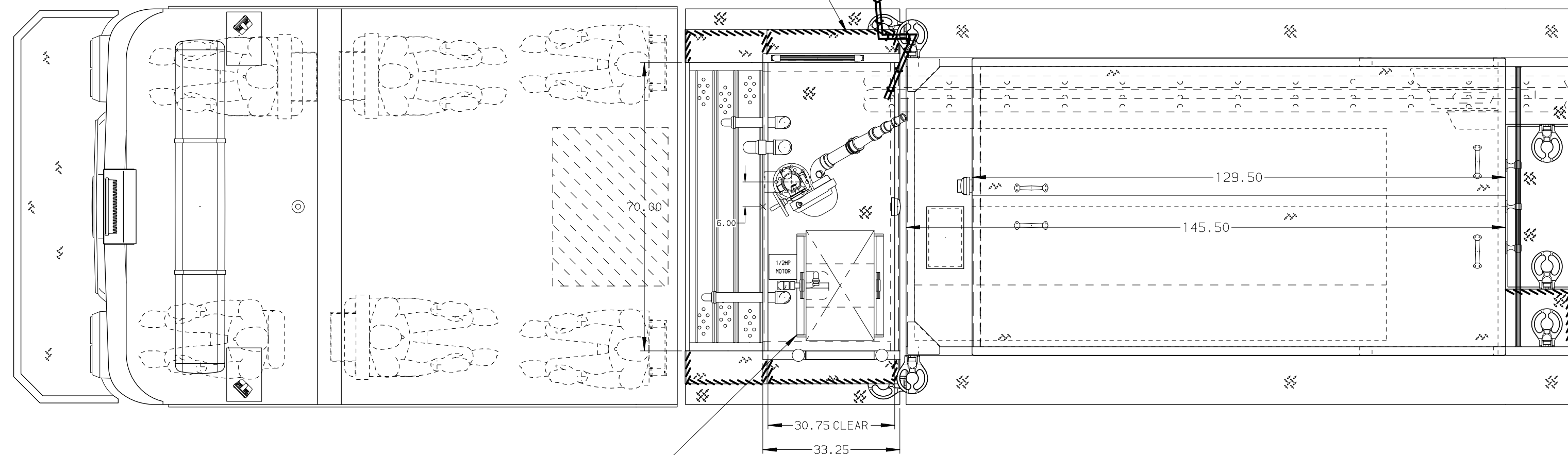

HOSEBED CAPACITIES

① - 1000' OF 5.00" D.J. POLY HOSE

② - 1000' OF 3.00" D.J. POLY HOSE

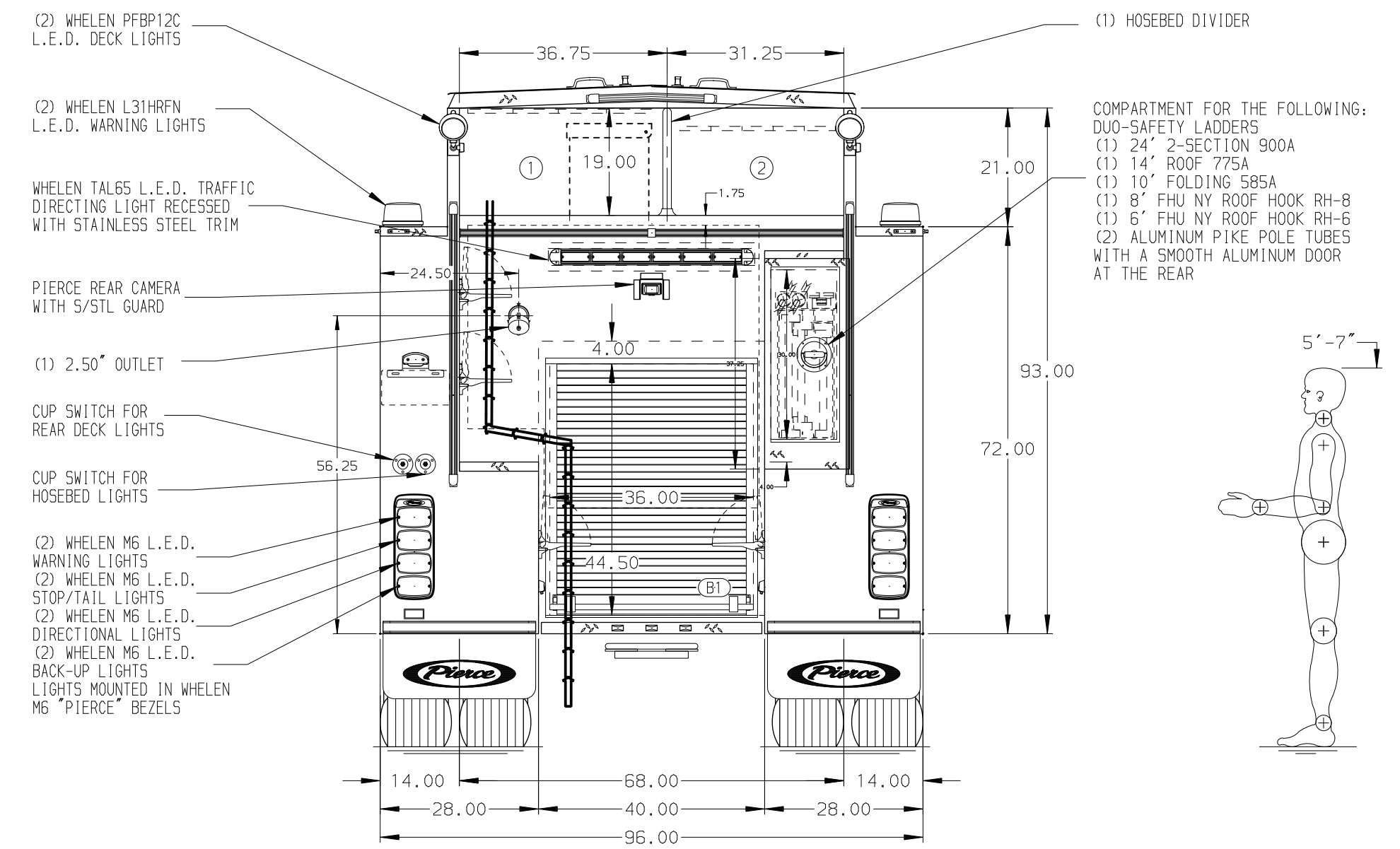

ALUMINUM BODY

SIDE ROLL AND FRONTAL IMPACT PROTECTION

NOTE
DIMENSIONS SHOWN ARE APPROXIMATE AND ARE SUBJECT TO MINOR DEVIATIONS AS MAY OCCUR OR BE NECESSARY IN CONSTRUCTION.
MINOR DETAILS NOT SHOWN.

- PACCAR DEF TANK MOUNTED UNDER CAB ON THE DRIVER'S SIDE
- BATTERY CHARGER LOCATED BEHIND DRIVER'S SEAT
- DUAL L.E.D. LIGHT STRIPS LOCATED IN HOSE BED
- L.E.D. LIGHT STRIP LOCATED ON THE FRONT OF THE HOSEBED
- DRIP PAN GUARD FOR ROLL-UP DOORS LOCATED PER SHOP ORDER
- AIR OUTLET WITH SHUT OFF VALVE LOCATED ON OS PUMP PANEL
- SEVEN ADJUSTABLE SHELVES LOCATED PER SHOP ORDER
- TWO FLOOR MOUNTED TRAYS LOCATED PER SHOP ORDER
- CTECH DRAWER ASSEMBLY LOCATED PER SHOP ORDER

CUSTOMER APPROVAL

APPROVED BY: _____
DATE: _____

CHASSIS DATA	TITLE	1500-D-1000P, 1000 GALLON WATER TANK, 161" FH/FDLER LADDERS BTWN TANK & SS, (3) XLAYS, HOSE REEL, DELUGE
MAKE	FOR	ODESSA FIRE DEPARTMENT ODESSA, TEXAS
PIERCE	DWG NO.	36755AD
MODEL	NO.	
ENFORCER		



JOB NO.	36755
SCALE	1:24
DATE	
DRAWN BY	JJB
CHECKED BY	KBO
SHEET SIZE	D
SHEET NO.	1 OF 1