

<b>BODY</b> 100' Ascendant Aerial Tower Alum Body COMPT, LEFT SIDE Full Height RollUp Doors COMPT, RIGHT SIDE Full Height RollUp Doors	<b>WATER TANK</b> 300 GalLon Poly Water Tank Foam System Foam System Not Required Foam Cell Foam Cell Not Required
---	---

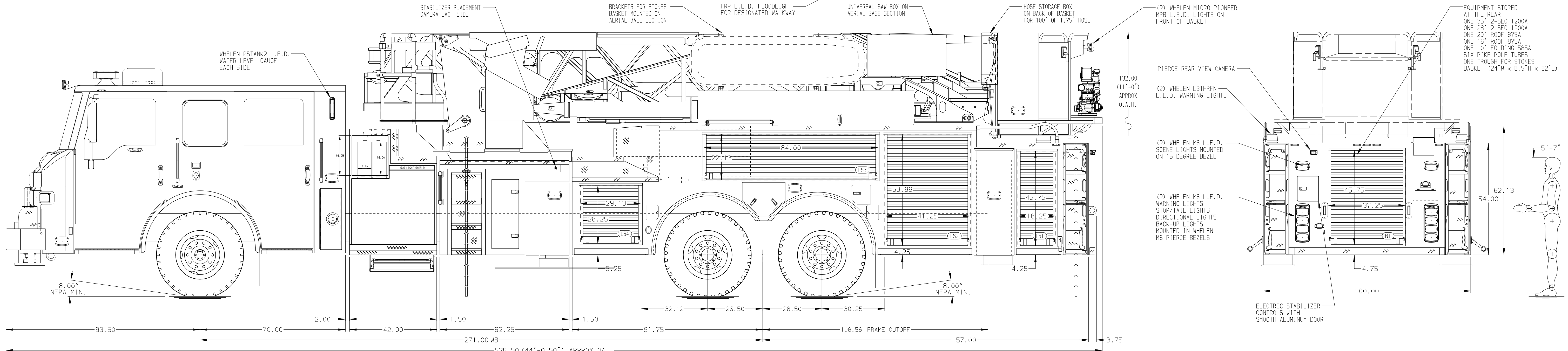

<b>CHASSIS</b> Velocity Chassis (Big Block) <b>ENGINE</b> 605 HP Cummins X15 Engine	<b>CAB</b> 7000 Velocity FR Cab <b>BUMPER</b> 15" Painted Aluminum	<b>AXLE, FRONT, CUSTOM</b> 24,000 Lb TAK-4 Axle <b>AXLE, REAR</b> 52,000 Lb Meritor Axle	<b>TRANSMISSION</b> Allison 5th Gen, 4000 EV5 P	<b>PUMPHOUSE</b> 42" Control Zone Side Mount <b>PUMP</b> 2000 GPM Waterous S100	<b>CROSSLAYS, 1.50"</b> (2) 1.50", With Trays, 200' <b>CROSSLAYS, 2.50"</b> 2.50" Crosslay Not Required	<b>SPEEDLAYS</b> Speedlays Not Required <b>GENERATOR</b> Generator Not Required	<b>CUSTOMER APPROVAL</b> APPROVED BY: _____ DATE: _____		JOB NO. 36994
<b>NOTE</b> DIMENSIONS SHOWN ARE APPROXIMATE AND ARE SUBJECT TO MINOR DEVIATIONS AS MAY OCCUR OR BE NECESSARY IN CONSTRUCTION. MINOR DETAILS NOT SHOWN.	1. SHORELINE RECEPTACLE WITH KUSSMAUL SUPER AUTO-EJECT LOCATED ON DRIVER SIDE OF THE CAB 2. AIR INLET/OUTLET MOUNTED IN A RECESSED ALUMINUM TREADPLATE BOX IN THE DRIVER SIDE STEPWELL 3. BATTERY CHARGER LOCATED BEHIND DRIVER'S SEAT 4. BATTERY CHARGE INDICATOR LOCATED ON DRIVER SIDE OF THE CAB 5. L.E.D. LIGHT STRIPS WITH STAINLESS STEEL PROTECTIVE COVER LOCATED IN HOSE BED 6. SEVEN ADJUSTABLE SHELVES IN COMPARTMENTS PER SHOP ORDER 7. FOUR FLOOR MOUNTED SLIDE-OUT TRAYS IN COMPARTMENTS PER SHOP ORDER 8. TWO ADJUSTABLE TOOL BOARDS MOUNTED TO SLIDE-OUT TRAY IN COMPARTMENTS PER SHOP ORDER 9. ONE SWING-OUT TOOL GRID SYSTEM IN COMPARTMENT PER SHOP ORDER	10. TWO POLY TOOL BOXES IN COMPARTMENTS PER SHOP ORDER 11. ONE 120V DUPLEX RECEPTACLE IN COMPARTMENT PER SHOP ORDER 12. AERIAL WIRELESS REMOTE CONTROLS LOCATED PER SHOP ORDER 13. DC POWER TO AERIAL BASKET 14. NON-RAISED AERIAL PEDESTAL 15. 3-in-1 LYFECOMBO BRACKETS AT AERIAL BASKET	<b>CHASSIS DATA</b> MAKE PIERCE MODEL VELOCITY	TITLE 100' ASCENDANT AERIAL TOWER AND BODY ASSEMBLY FOR CITY OF AUSTELL FIRE DEPARTMENT DWG NO. 36994AD	SCALE 1:24 DATE DRAWN BY TKA CHECKED BY NDA SHEET SIZE D SHEET NO. 1 OF 1				