

Pumper, PUC

BODY

Pumper, PUC, Aluminum

CHASSIS

Enforcer Chassis, PUC

CHASSIS AXLE, FRONT, CUSTOM

18,000 Lb TAK-4 Axle

AXLE, REAR

27,000 Lb Meritor Axle

ENGINE

450 HP Cummins L9 Engine

TRANSMISSION

Allison 5th Gen, 3000 EVS P

BUMPER

19" Extended Stainless Steel

CAB

7010 Enforcer Cab, PUC

BODY

WATER TANK

750 Gallon Poly Water Tank

COMPT, PUMPER, REAR

33.50' FF RollUp Rear Compt w/Tailboard, PUC

COMPT, PUMPER, LEFT SIDE

189" RollUp Full Height & Depth Front & Rear, PUC

COMPT, PUMPER, RIGHT SIDE

189" RollUp Full Height & Depth Front & Rear, PUC

FIRE SUPPRESSION

PUMPHOUSE

Control Zone, PUC

PUMP

1500 GPM Pierce PUC

CROSSLAYS, 1.50"

(2) 1.50", Poly Trays, 200'

CROSSLAYS, 2.50"

(1) 2.50", Poly Tray, 200'

GENERATOR

Generator Not Required

Foam System

Husky 3 Foam System

Foam Cell

20 Gal Foam Reduce Water

NOTE
DIMENSIONS SHOWN ARE APPROXIMATE AND ARE SUBJECT TO MINOR DEVIATIONS AS MAY OCCUR OR BE NECESSARY IN CONSTRUCTION. MINOR DETAILS NOT SHOWN.

- ONE 1.50" OUTLET WITH 2.00" PIPING AND SWIVEL LOCATED IN CENTER BUMPER TRAY
- BLUE SEA SURE EJECT SHORELINE LOCATED ON DRIVER SIDE OF THE CAB
- AIR INLET WITH DISCONNECT COUPLING IN THE DRIVER SIDE STEPMILL
- BATTERY CHARGER LOCATED IN COMPARTMENT PER SHOP ORDER
- BATTERY CHARGE INDICATOR LOCATED ON THE DRIVER SIDE SEAT RISER
- FOUR ADJUSTABLE SHELVES IN COMPARTMENTS PER SHOP ORDER
- TWO FLOOR MOUNTED SLIDE-OUT TRAY IN COMPARTMENT PER SHOP ORDER
- TWO SWING-OUT TOOLBOARDS IN COMPARTMENTS PER SHOP ORDER

123.00
(10'-3")
APPROX
O.A.H.

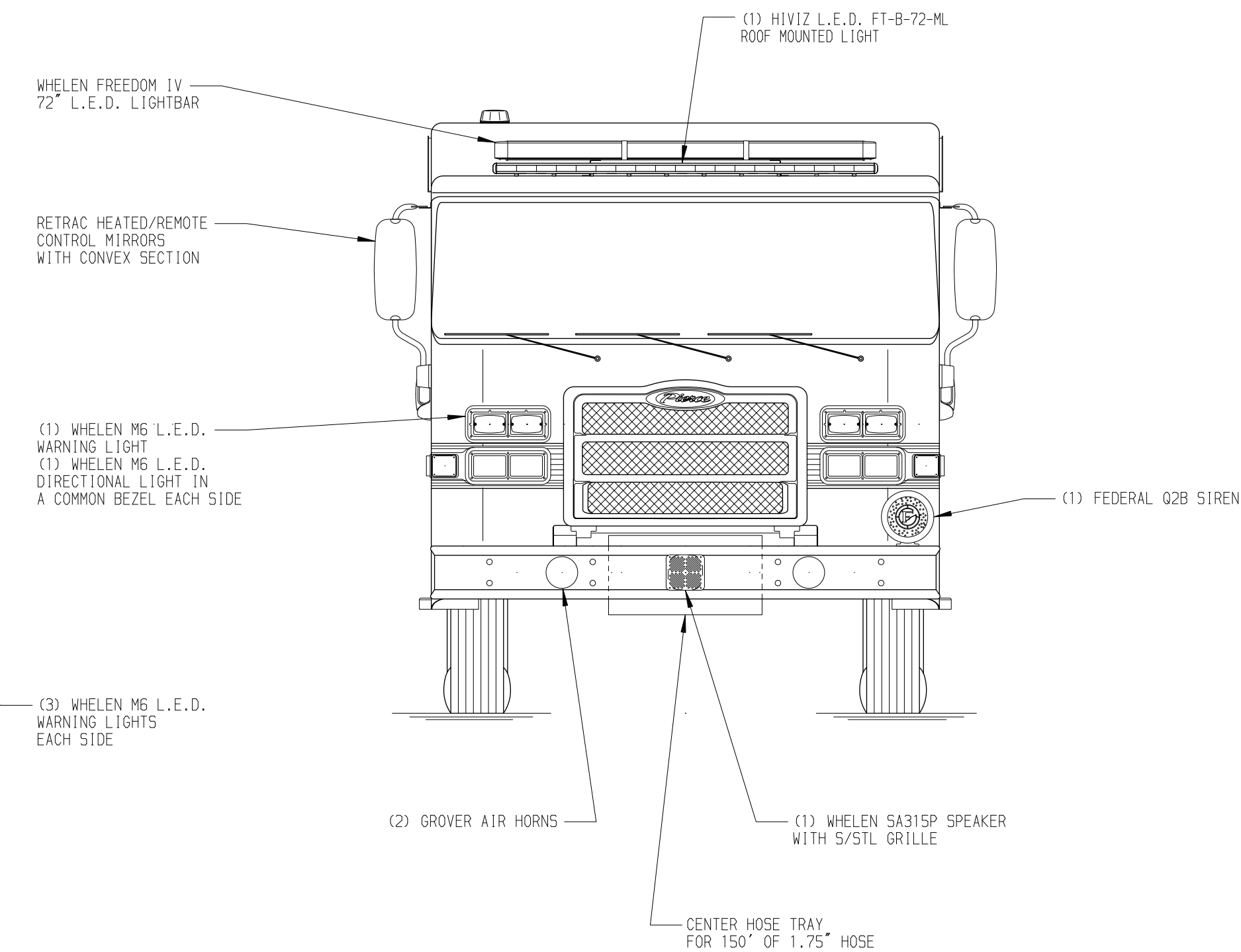
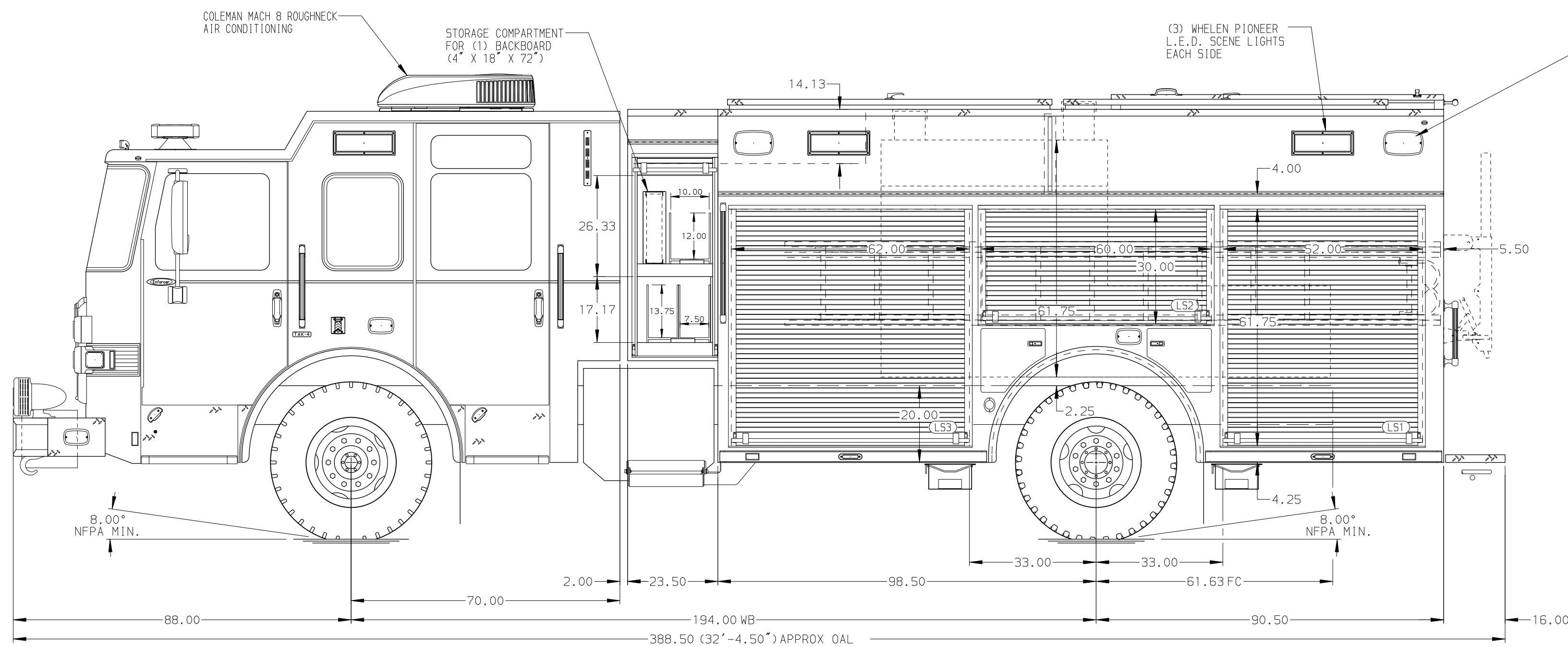
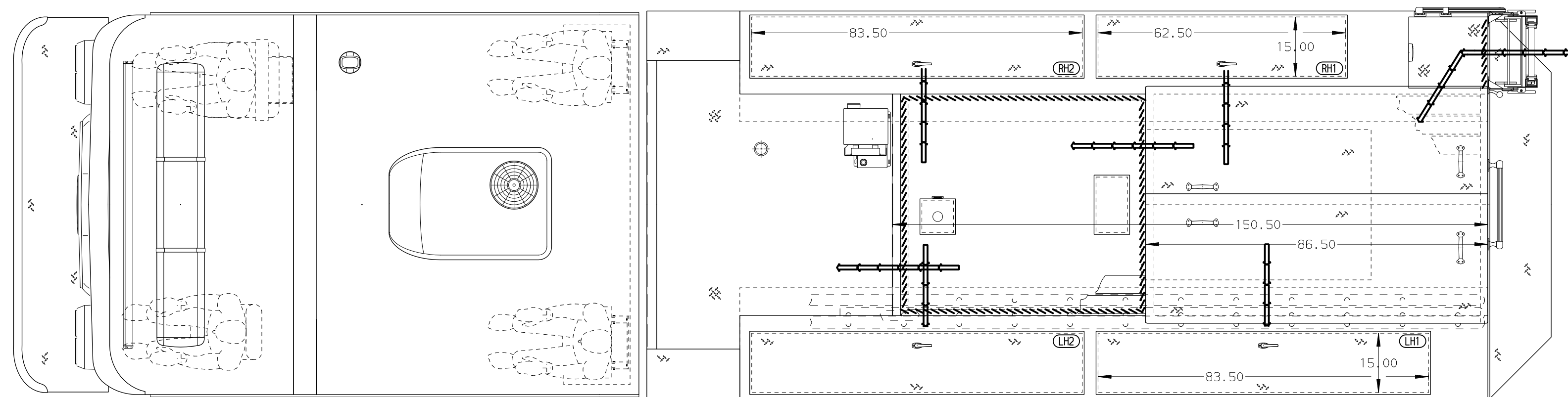
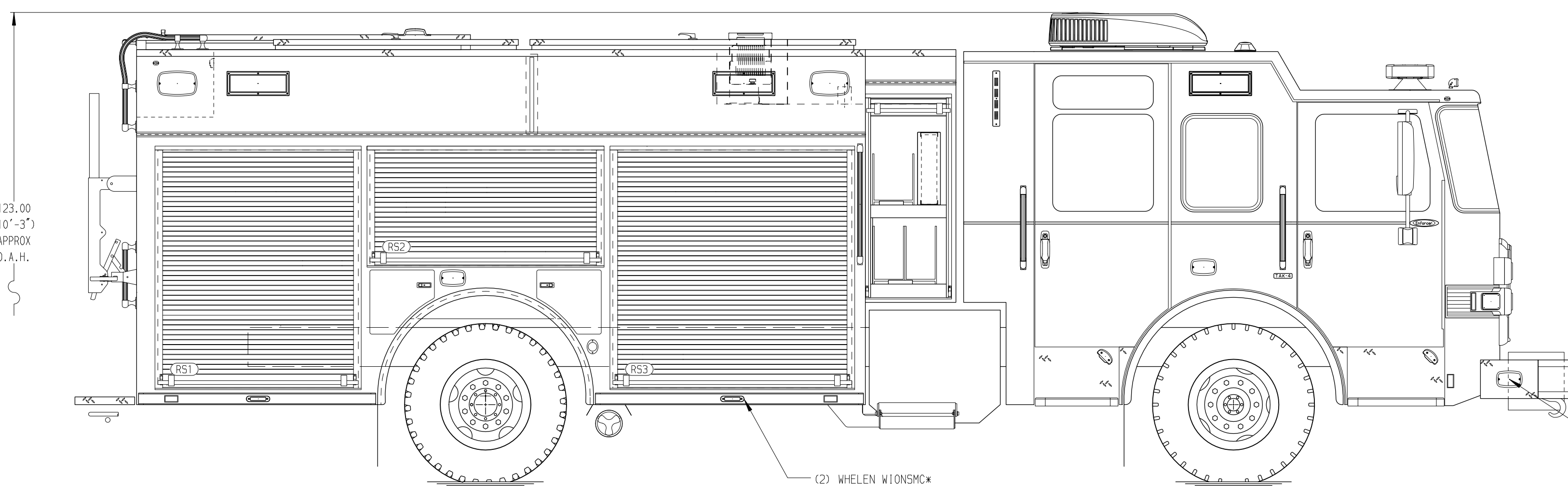

HOSEBED CAPACITY	
BED 1	800' OF 4.00" D.J. POLY HOSE
BED 2	1200' OF 2.50" D.J. POLY HOSE

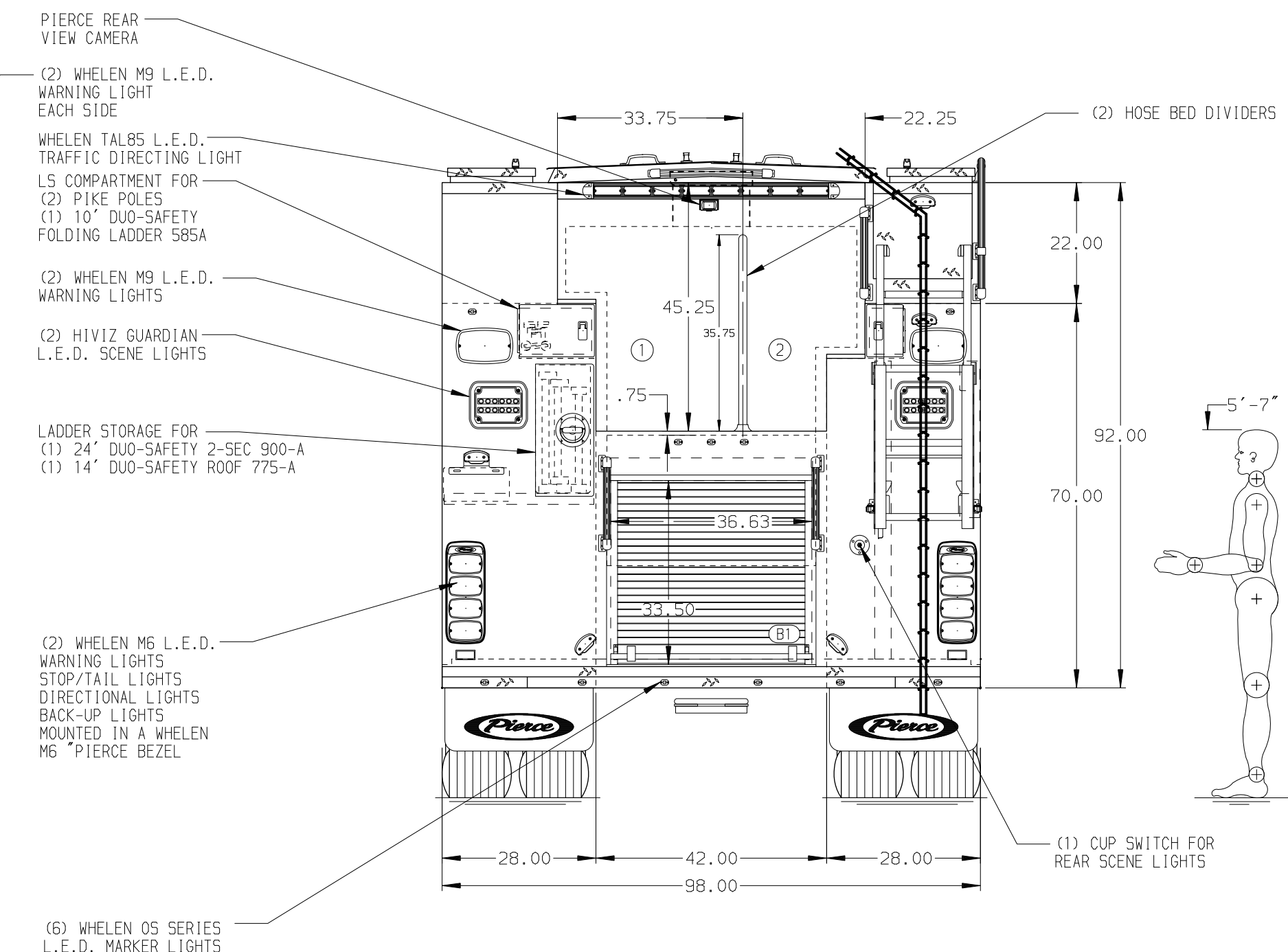

CUSTOMER APPROVAL

APPROVED BY: _____
DATE: _____



JOB NO.	37093
SCALE	1:24
DATE	
DRAWN BY	COL
CHECKED BY	THS
SHEET SIZE	D
SHEET NO.	1 OF 1

REV	DATE	BY	CH	ENFORCER	TITLE	FOR	DWG NO.
					CHASSIS DATA	Pierce PUC Pumper Approval Drawing	
					MAKE	EL Centro Fire Department	
					MODEL		

37093AD