

**PUMPER
BODY**

Long Aluminum 2nd Gen Pumper

CHASSIS

Enforcer Chassis

**CHASSIS
AXLE, FRONT, CUSTOM**

19,500 Lb TAK-4 Axle

AXLE, REAR

27,000 Lb Meritor Axle

ENGINE

510 HP PACCAR MX13 Engine

TRANSMISSION

Allison 5th Gen, 4500 EVS P

BUMPER

19" Extended Painted Steel

CAB

7010 Enforcer Cab

BODY

WATER TANK

1000 Gallon Poly Water Tank

COMPT, PUMPER, REAR

30.75" FF RollUp Rear Compt

COMPT, PUMPER, LEFT SIDE

161" RollUp Full Height Front & Rear FDLR

COMPT, PUMPER, RIGHT SIDE

161" RollUp Full Height Front & Rear FDLR

**FIRE SUPPRESSION
PUMPHOUSE**

52" Control Zone Side Mount

PUMP

1500 GPM Waterous CSU

CROSSLAYS, 1.50"

(2) 1.50" Standard Capacity

CROSSLAYS, 2.50"

(1) 2.50" Standard Capacity

SPEEDLAYS

Speedlays Not Required

GENERATOR

Generator Not Required

Foam System

Foam System Not Required

Foam Cell

Foam Cell Not Required

Side Roll and Frontal Impact Protection

NOTE

DIMENSIONS SHOWN ARE APPROXIMATE AND ARE SUBJECT TO MINOR DEVIATIONS AS MAY OCCUR OR BE NECESSARY IN CONSTRUCTION. MINOR DETAILS NOT SHOWN.

- ONE 1.50 OUTLET WITH 2.00 PIPING AND SWIVEL LOCATED IN CENTER BUMPER TRAY
- SHORELINE RECEPTACLE WITH KUSSMAUL SUPER AUTO-EJECT LOCATED ON DRIVER SIDE OF THE CAB
- AIR INLET WITH DISCONNECT COUPLING IN THE DRIVER SIDE STEPWELL
- BATTERY CHARGER LOCATED BEHIND DRIVER'S SEAT
- BATTERY CHARGE INDICATOR DISPLAYED THROUGH DRIVER SIDE WINDOW
- SIX ADJUSTABLE SHELVES IN COMPARTMENTS PER SHOP ORDER
- FOUR FLOOR MOUNTED SLIDE-OUT TRAYS LOCATED PER SHOP ORDER

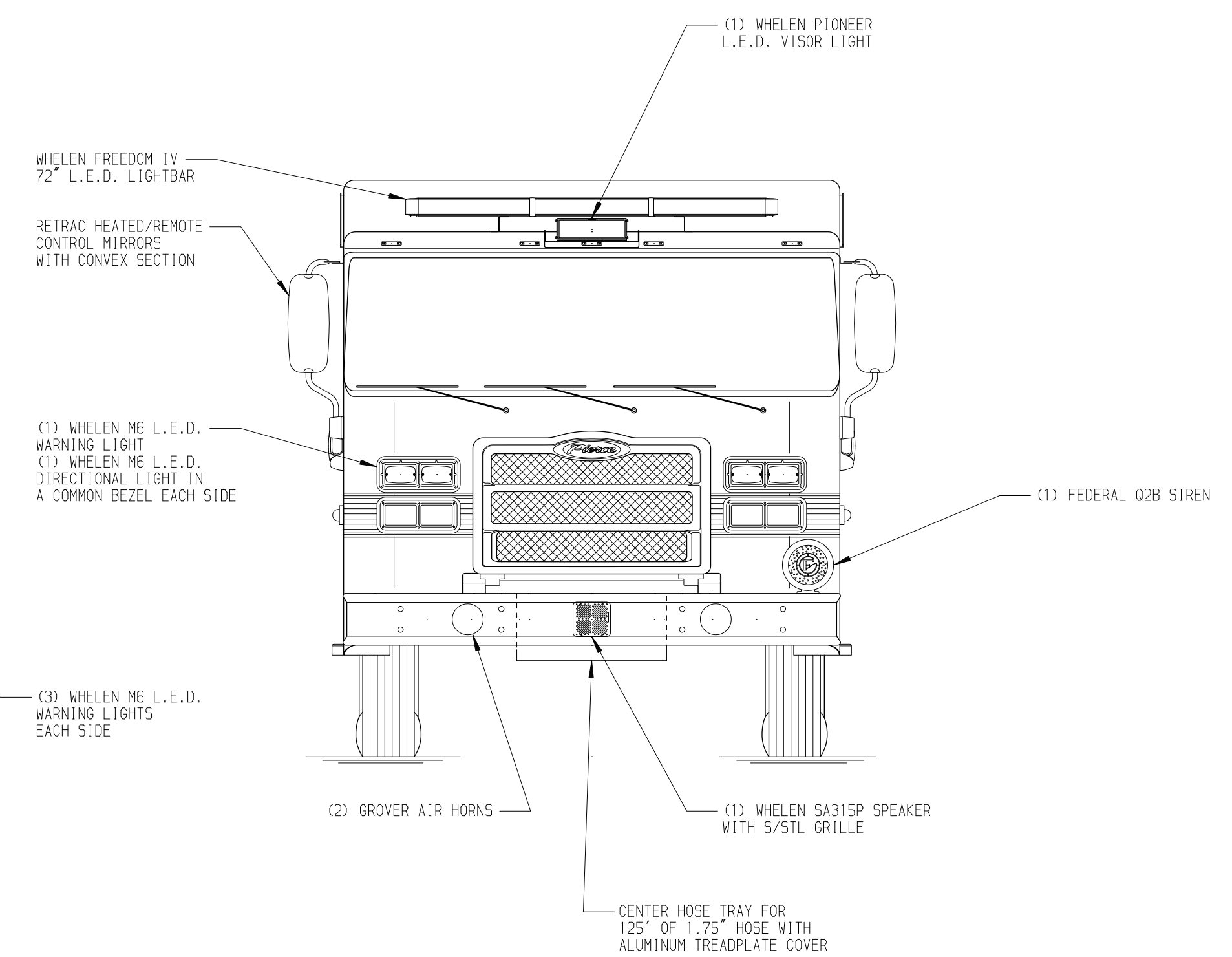
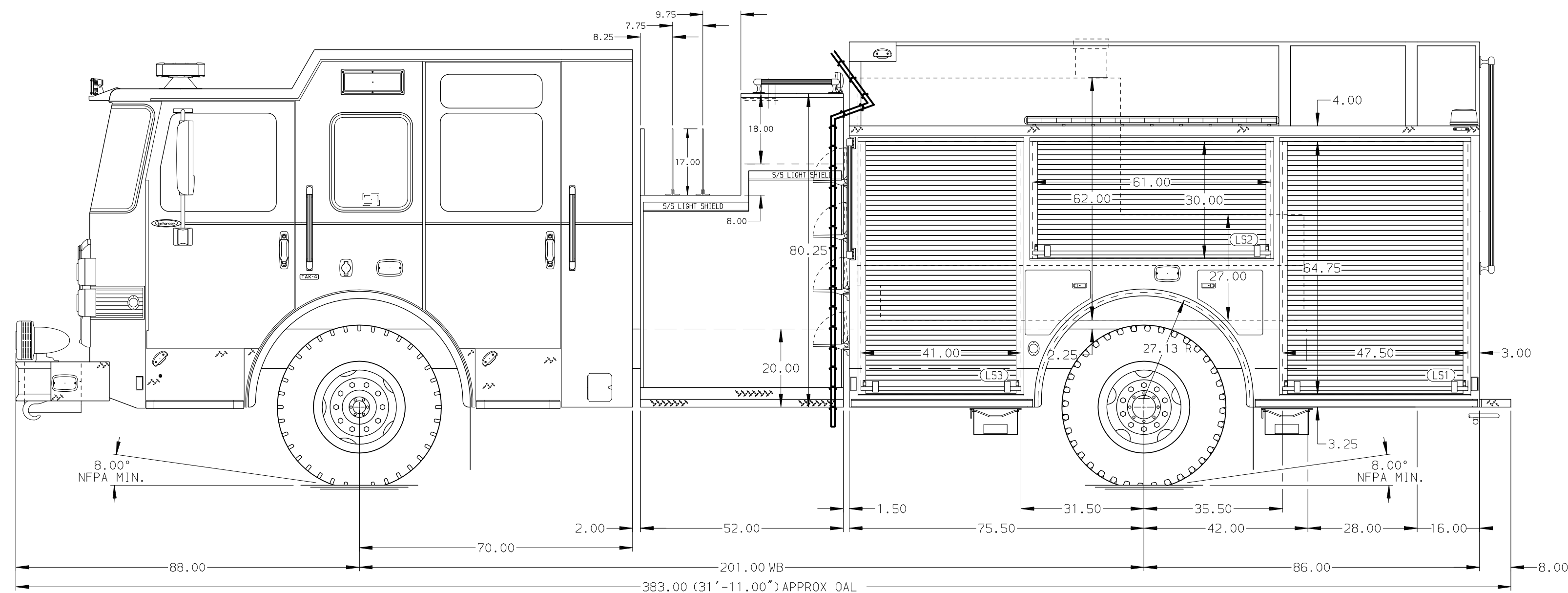
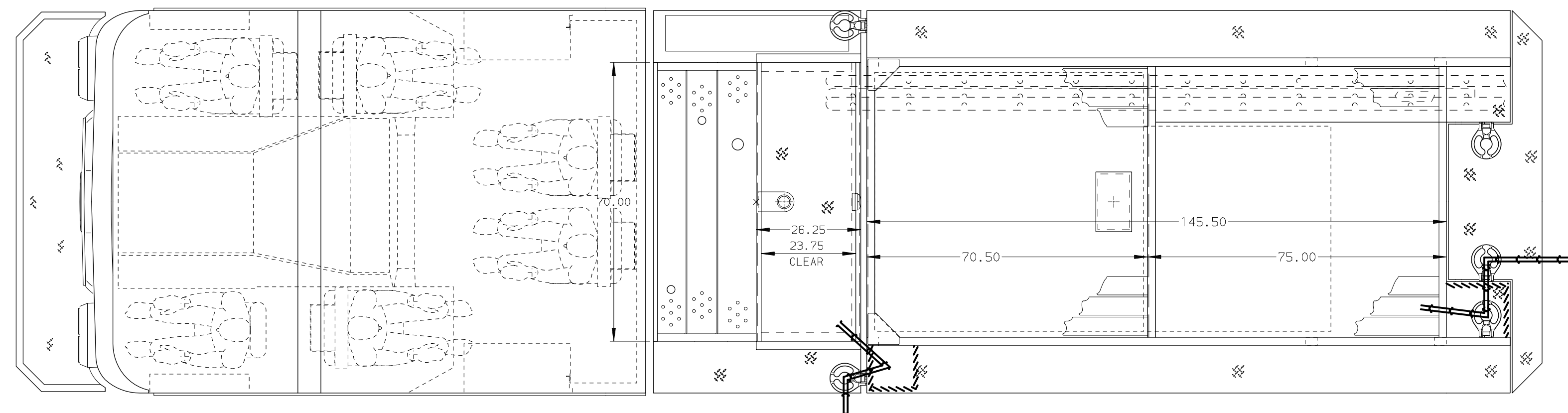
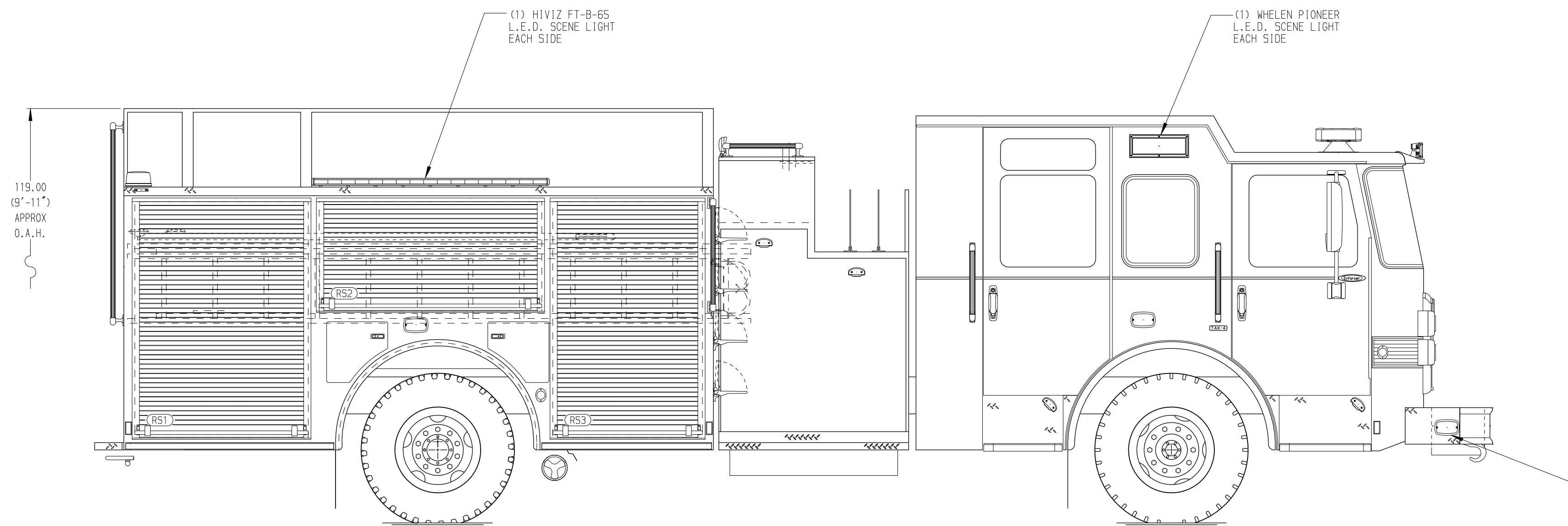

HOSEBED CAPACITY

BED 1	300' OF 3.00" D.J. POLY HOSE
BED 2	1000' OF 5.00" D.J. POLY HOSE
BED 3	250' OF 3.00" D.J. POLY HOSE

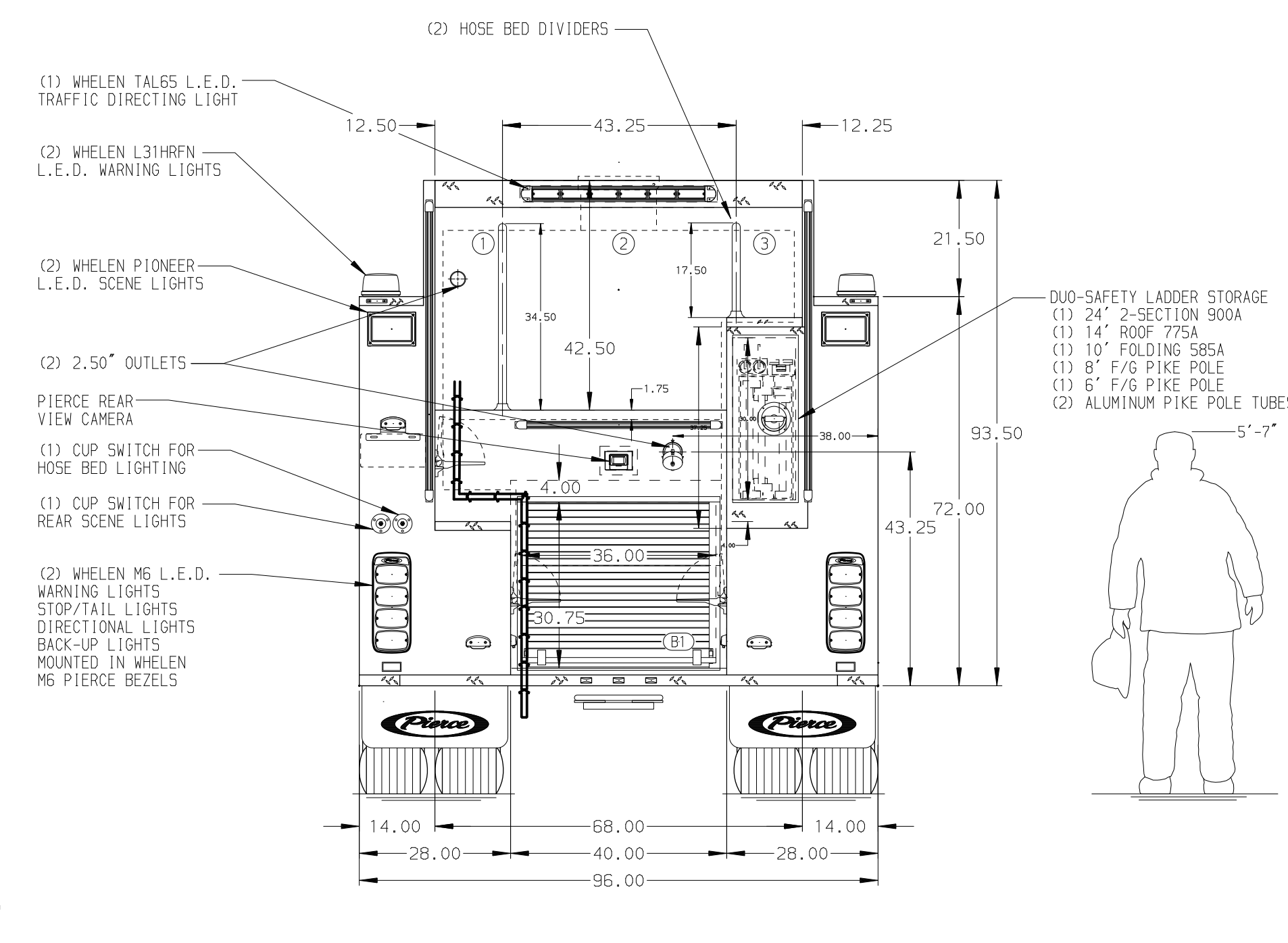

CUSTOMER APPROVAL

APPROVED BY: _____
DATE: _____



JOB NO. 37192

SCALE 1:24 DATE

CHASSIS DATA	TITLE	Pierce Pumper Approval Drawing
MAKE	FOR	Pierce Field Unit
PIERCE	DWG NO.	37192AD
MODEL		
ENFORCER		

DRAWN BY COL	DATE 17AUG21
CHECKED BY THS	DATE 20AUG21
SHEET SIZE D	SHEET NO. 1 OF 1