

HOSEBED CAPACITIES
 ① 1500' OF 2.50" D.J. POLYESTER HOSE
 ② 400' OF 1.50" D.J. RUBBER HOSE

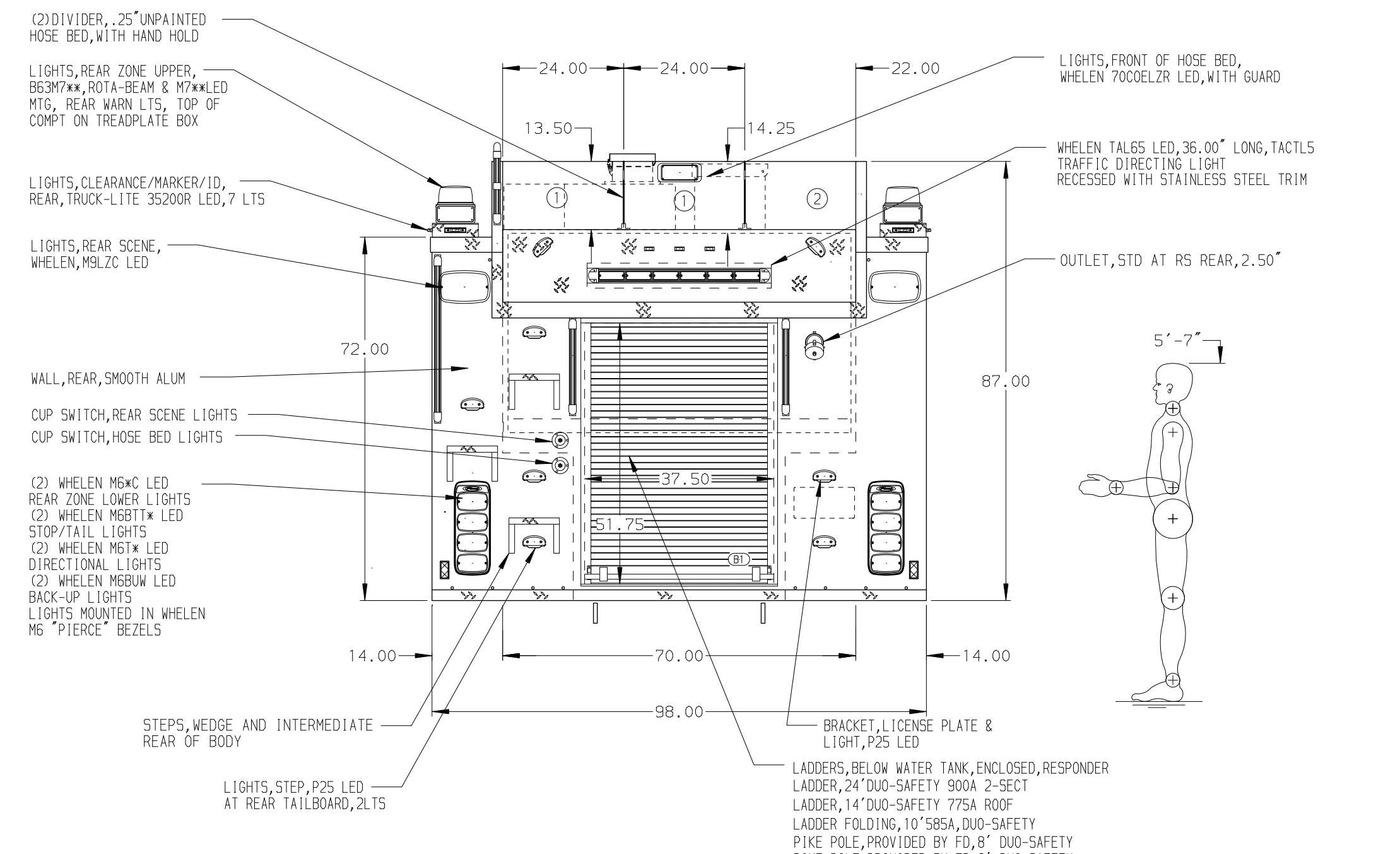
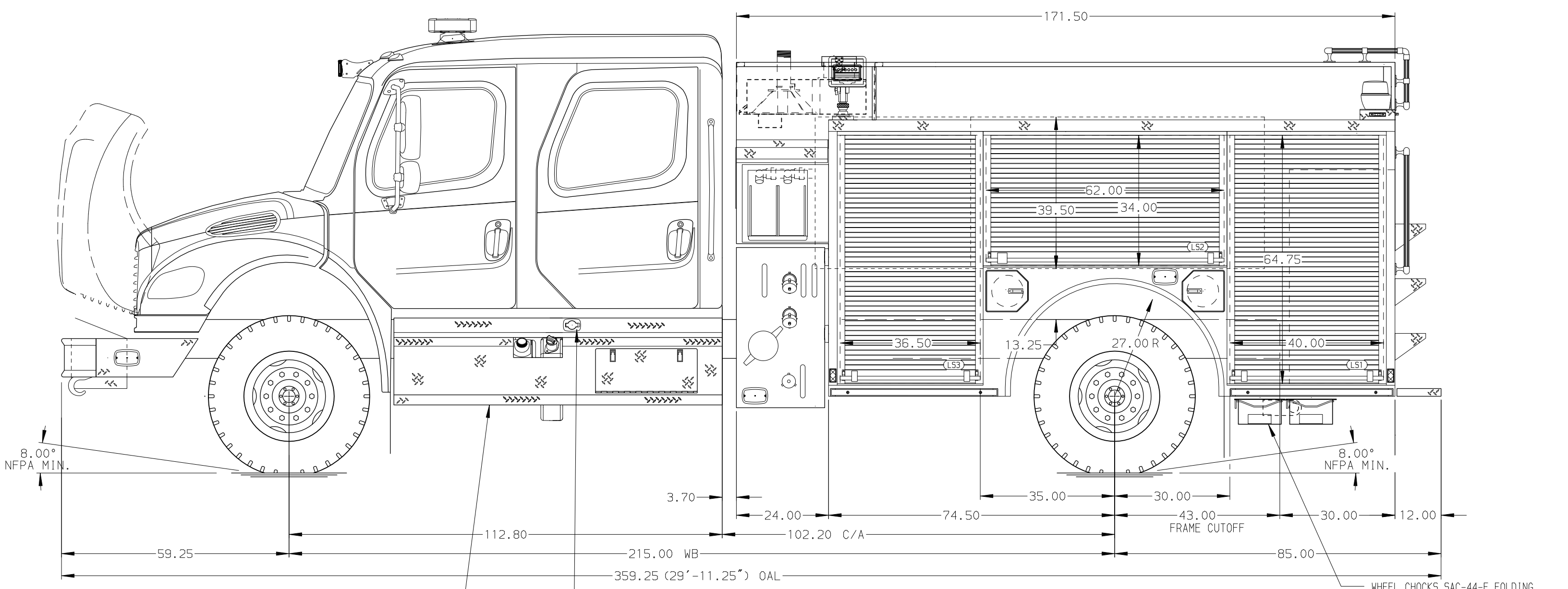

FUEL TANK, 50GAL, ALUM, LH ONLY, FL
 DEF TANK, 6.0 GALLON, LH, FL
 STEP PACKAGE, DELUXE, ALUM 4-WAY,
 (INCLUDING DEF) M2, 2-DOOR (EXTD CAB W/OPTIONS)

SHORELINE, 204, 120V, BLUE SEA SURE EJECT SHORELINE

ALUMINUM BODY

NOTE
 DIMENSIONS SHOWN ARE APPROXIMATE AND ARE SUBJECT TO MINOR DEVIATIONS AS MAY OCCUR OR BE NECESSARY IN CONSTRUCTION. MINOR DETAILS NOT SHOWN.

1000 GAL=1882673
 20 GAL FOAM=1918462

CHASSIS DATA	TITLE	1250-D-1000 POLY 147.5" BODY DS & PS FULL HEIGHT
MAKE	FOR	(2) SPEEDLAYS
FL		SIDDONS-MARTIN SALES HOUSTON, TEXAS
MODEL	DWG NO.	37371AD
REV	DATE	BY
		CH

Pierce MANUFACTURING INC.
 BRADENTON, FLORIDA

JOB NO.	37371
SCALE	1:24
DATE	22JUN22
DRAWN BY	JLA
CHECKED BY	RWI
SHEET SIZE	D
SHEET NO.	1 OF 1