

RIGHT SIDE COMPARTMENTS CONTAIN THE FOLLOWING:

COMPARTMENT RS1 CONTAINS:
 - (1) HORIZONTAL FLOOR EXTENSION
 - (1) 42" DP ADJ SHELF
 - (1) 2-WAY FLOOR MTD SLIDEMASTER TRAY
 - (1) ELECTRIC CORD REEL WITH 200' OF 10/3 YELLOW CORD

COMPARTMENT RS2 CONTAINS:
 - (1) 42" DP ADJ SHELF

COMPARTMENT RS3 CONTAINS:
 - (1) HORIZONTAL FLOOR EXTENSION
 - (1) 42" DP ADJ SHELF
 - NYLATRON GUIDE ON FLOOR
 - (1) 2-WAY ADJ SLIDEMASTER TRAY
 - (1) 20A, 120V 6-PLACE RECEPTACLE

COMPARTMENT RS4 CONTAINS:

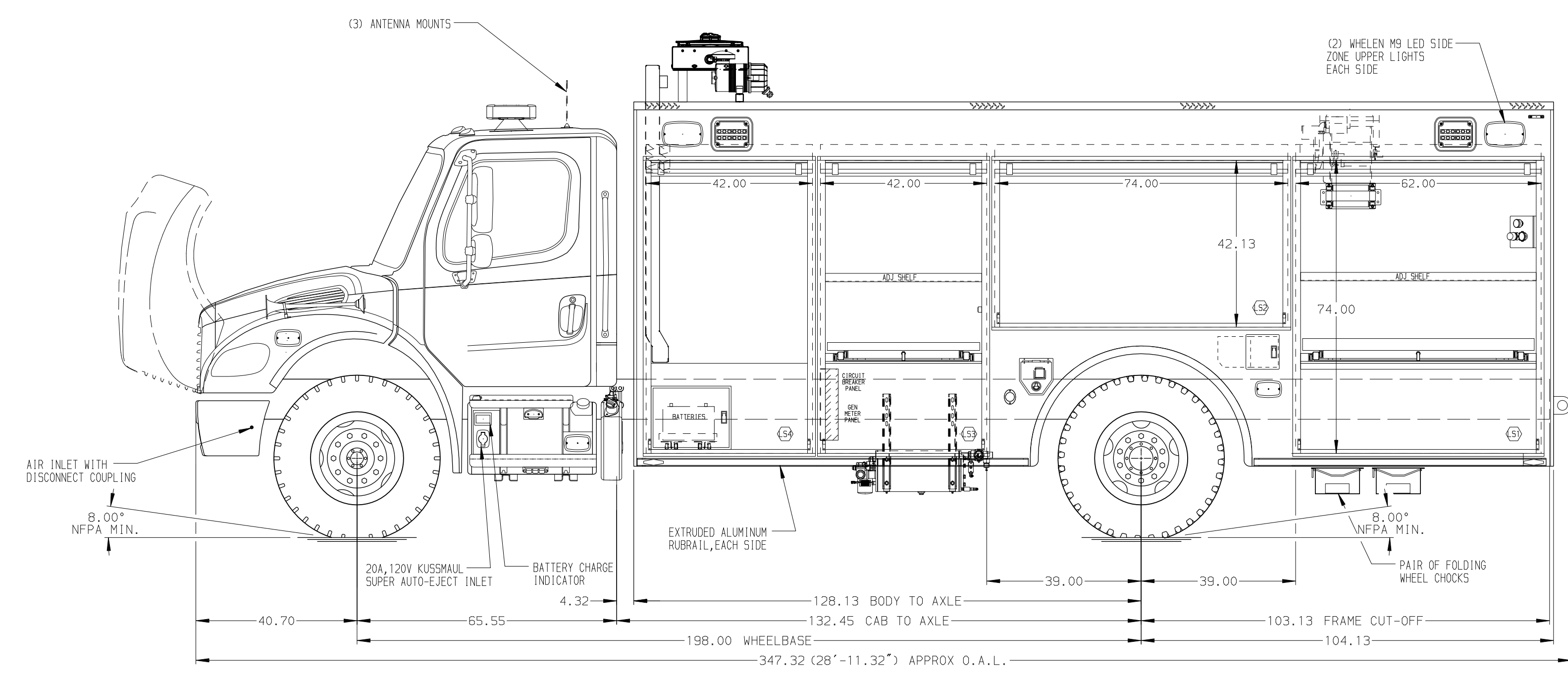
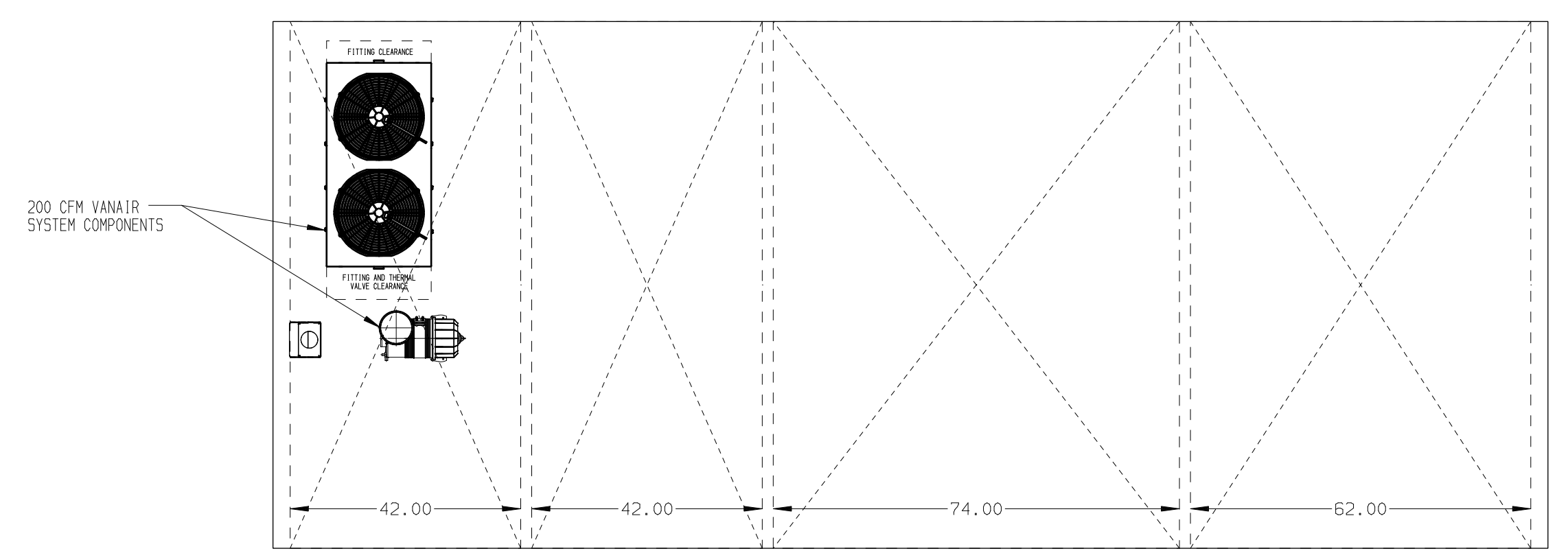
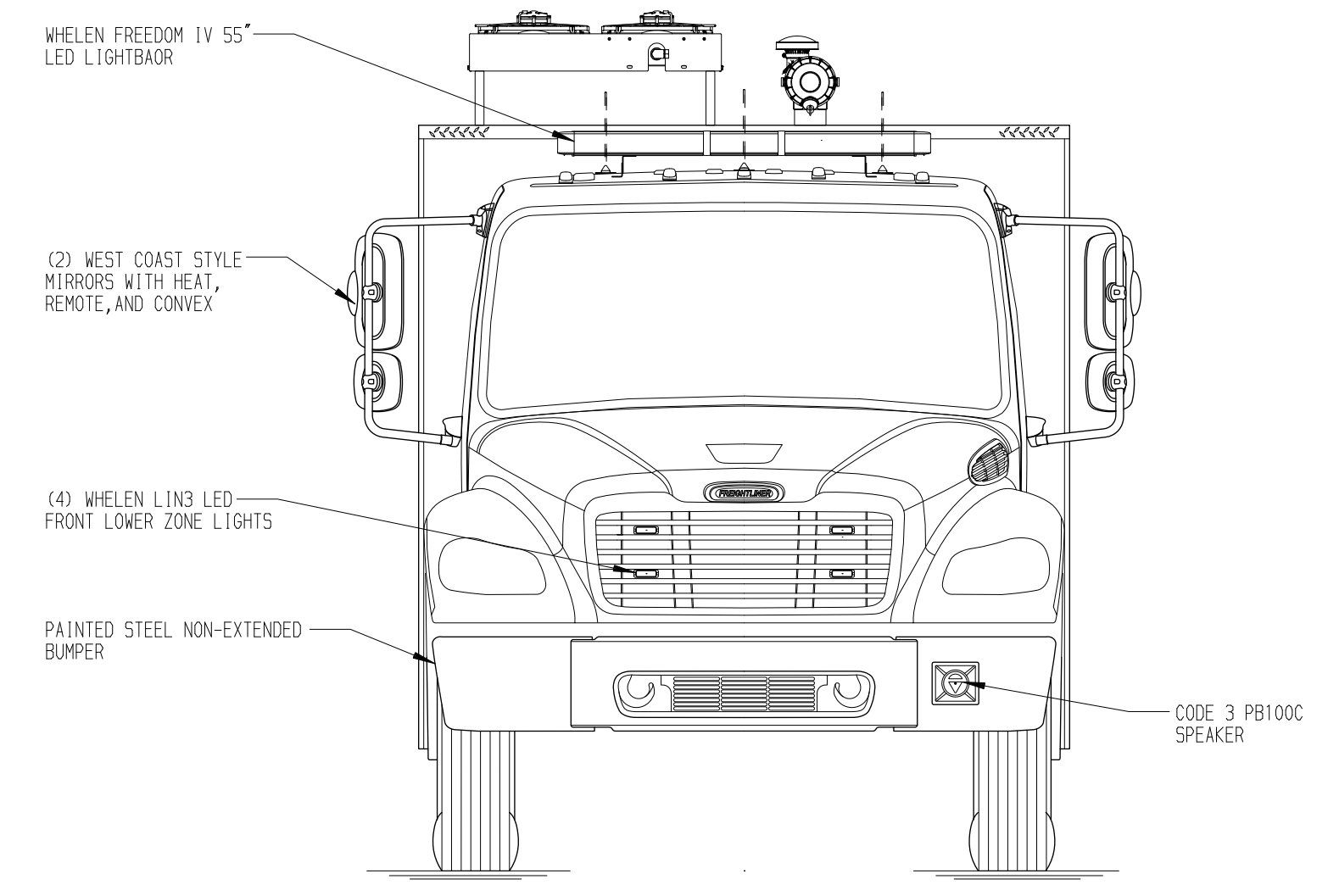
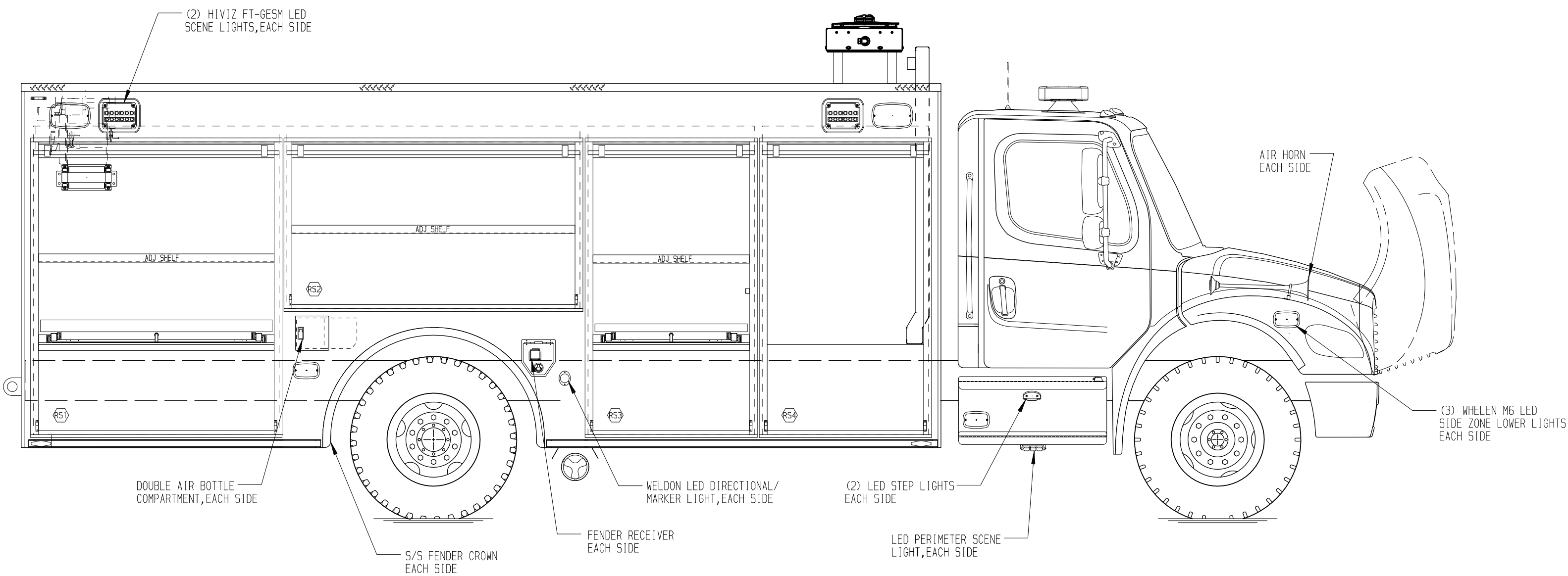

LEFT SIDE COMPARTMENTS CONTAIN THE FOLLOWING:

COMPARTMENT LS1 CONTAINS:
 - (1) 42" DP ADJ SHELF
 - (1) HORIZONTAL FLOOR EXTENSION
 - (1) 2-WAY FLOOR MTD SLIDEMASTER TRAY
 - (1) ELECTRIC CORD REEL WITH 200' OF 10/3 YELLOW CORD
 - TOOL AIR OUTLET WITH REGULATOR AND GAUGE

COMPARTMENT LS2 CONTAINS:
 - (1) 42" DP ADJ SHELF

COMPARTMENT LS3 CONTAINS:
 - (1) 42" DP ADJ SHELF
 - NYLATRON GUIDE ON FLOOR
 - (1) 2-WAY ADJ SLIDEMASTER TRAY
 - (1) 20A, 120V 6-PLACE RECEPTACLE
 - (1) CIRCUIT BREAKER PANEL
 - (1) GENERATOR METER PANEL

COMPARTMENT LS4 CONTAINS:
 - (1) KUSSMAUL PUMP PLUS 1200 CHARGER
 - CHASSIS BATTERIES

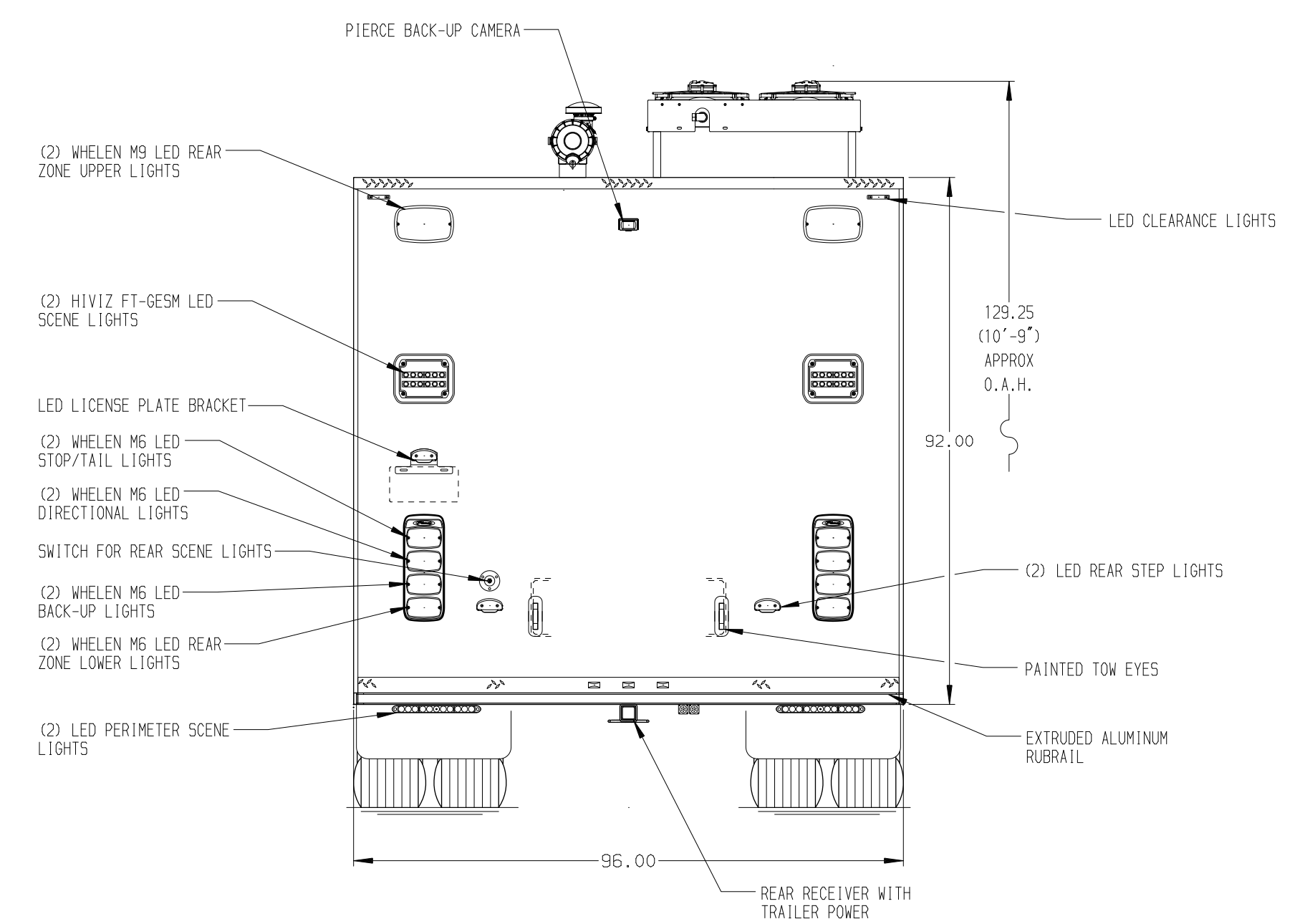

NOTE
 DIMENSIONS SHOWN ARE APPROXIMATE AND ARE SUBJECT TO MINOR DEVIATIONS AS MAY OCCUR OR BE NECESSARY IN CONSTRUCTION. MINOR DETAILS NOT SHOWN.

NOTES:
 1. PIERCE LED LIGHTS IN ALL BODY COMPARTMENTS
 2. ONAN 15kW SINGLE PHASE PTO DRIVEN GENERATOR LOCATED BETWEEN THE FRAME RAILS

CLEAR DOOR WIDTH KEY

AMOR ROLL UP DOORS:	-2 1/4"
CORTITE ROLL UP DOORS:	-2 1/2"
PIERCE DOUBLE LIP DOORS:	-4 1/4"
PIERCE LIFT-UP LIP DOORS:	-1 1/2"

(EX: 60" F-F - 2 1/4" = 57 3/4" CLEAR)
 (F-F) = FRAME TO FRAME

CUSTOMER APPROVAL

APPROVED BY: _____
 DATE: _____

REV	DATE	BY	CH
-	-	-	-

Pierce MANUFACTURING INC.

JOB NO. 37412

SCALE 1:24 DATE _____

DRAWN BY DHE 12APR22

CHECKED BY CDK 14APR22

SHEET SIZE D SHEET NO. 1 OF 1

TITLE ENCORE RESCUE VEHICLE 42.42.74.62

FOR COUNTY OF ORANGE BID #520

FRIGHTLINER MODEL M2-106

DWG NO. 37412AD

JEREMY COHEN

SIDE ROLL PROTECTION