

# Pumper, PUC

## BODY

Pumper, PUC, Aluminum

## CHASSIS

Enforcer Chassis, PUC

## CHASSIS

### AXLE, FRONT, CUSTOM

19,500 Lb TAK-4 Axle

### AXLE, REAR

27,000 Lb Dana Axle

## ENGINE

450 HP Cummins L9 Engine

## TRANSMISSION

Allison 5th Gen, 3000 EVS P

## BUMPER

26" Extended Stainless Steel

## CAB

7010 Enforcer Cab, PUC

## BODY

### WATER TANK

750 Gallon Poly Water Tank  
COMPT, PUMPER, REAR

### COMPT, PUMPER, LEFT SIDE

189" Lap/RollUp Full Height & Depth Front & Rear, PUC

### COMPT, PUMPER, RIGHT SIDE

189" Lap Full Height & Depth Front & Rear, PUC

## FIRE SUPPRESSION

### PUMPHOUSE

Control Zone, PUC

### PUMP

1500 GPM Pierce PUC

### CROSSLAYS, 1.50"

(1) 1.50", Poly Tray, 200'

### CROSSLAYS, 2.50"

(1) 2.50", Poly Tray, 200'

## GENERATOR

Generator Not Required

## Foam System

Foam System Not Required

## Foam Cell

Foam Cell Not Required

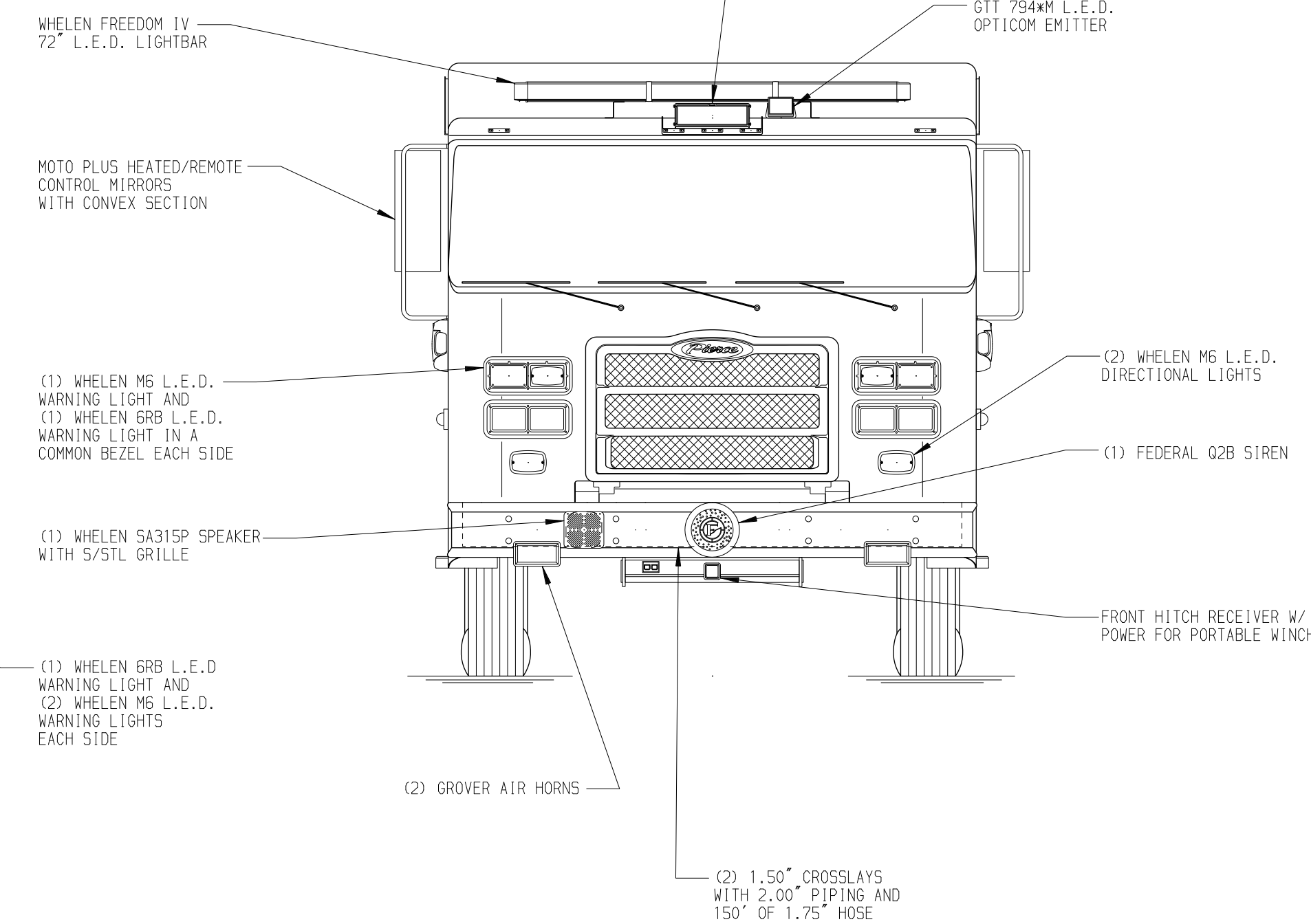
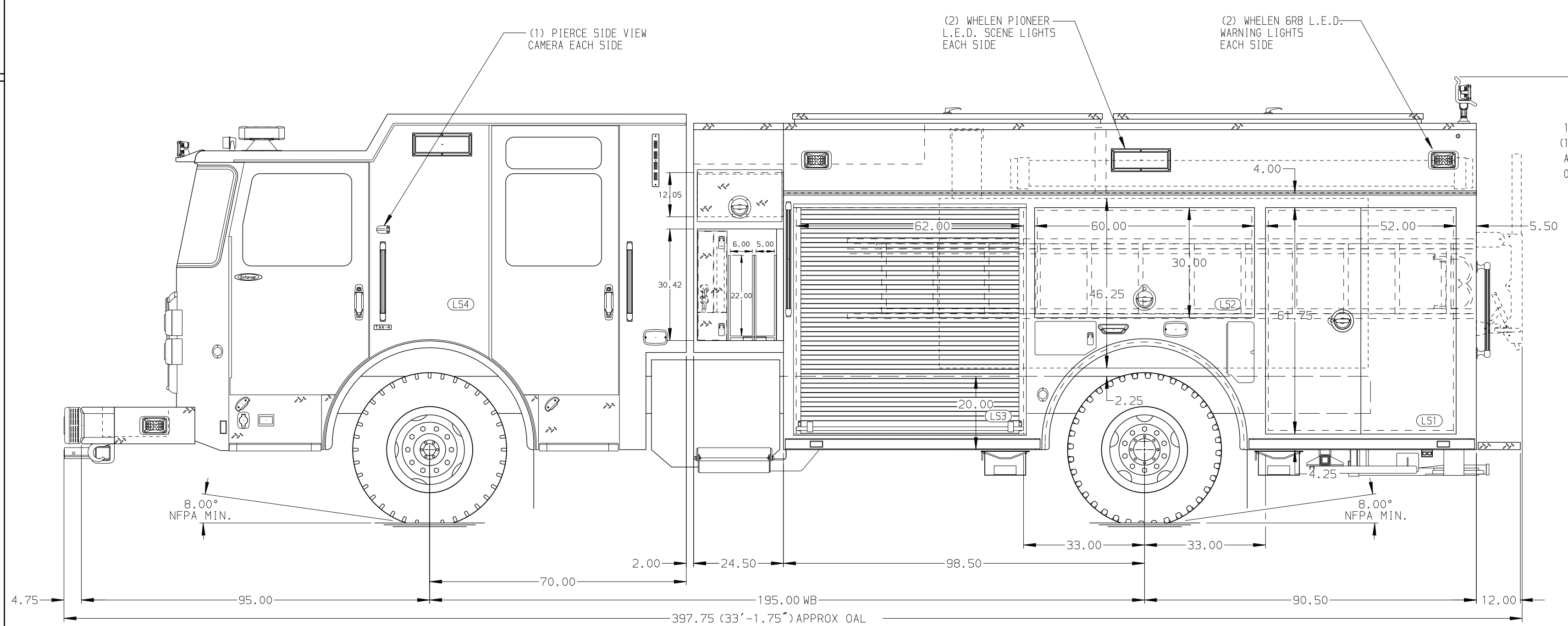
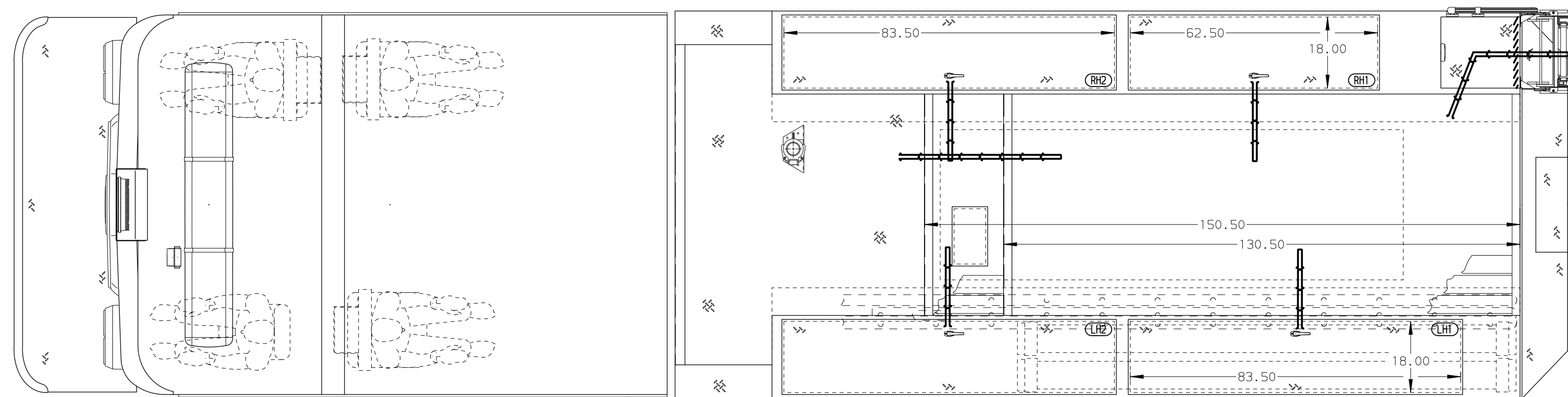
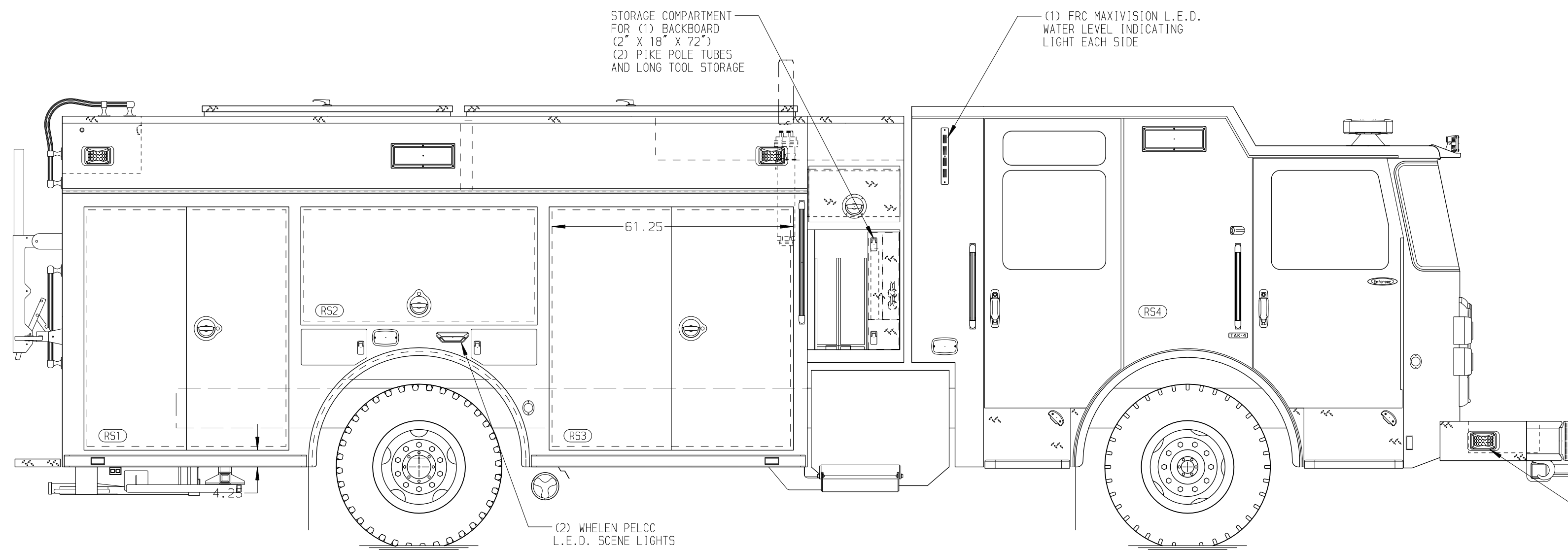

| HOSEBED CAPACITY |                               |
|------------------|-------------------------------|
| BED 1            | 300' OF 2.50" D.J. POLY HOSE  |
| BED 2            | 1000' OF 4.00" D.J. POLY HOSE |
| BED 2            | 300' OF 2.50" D.J. POLY HOSE  |

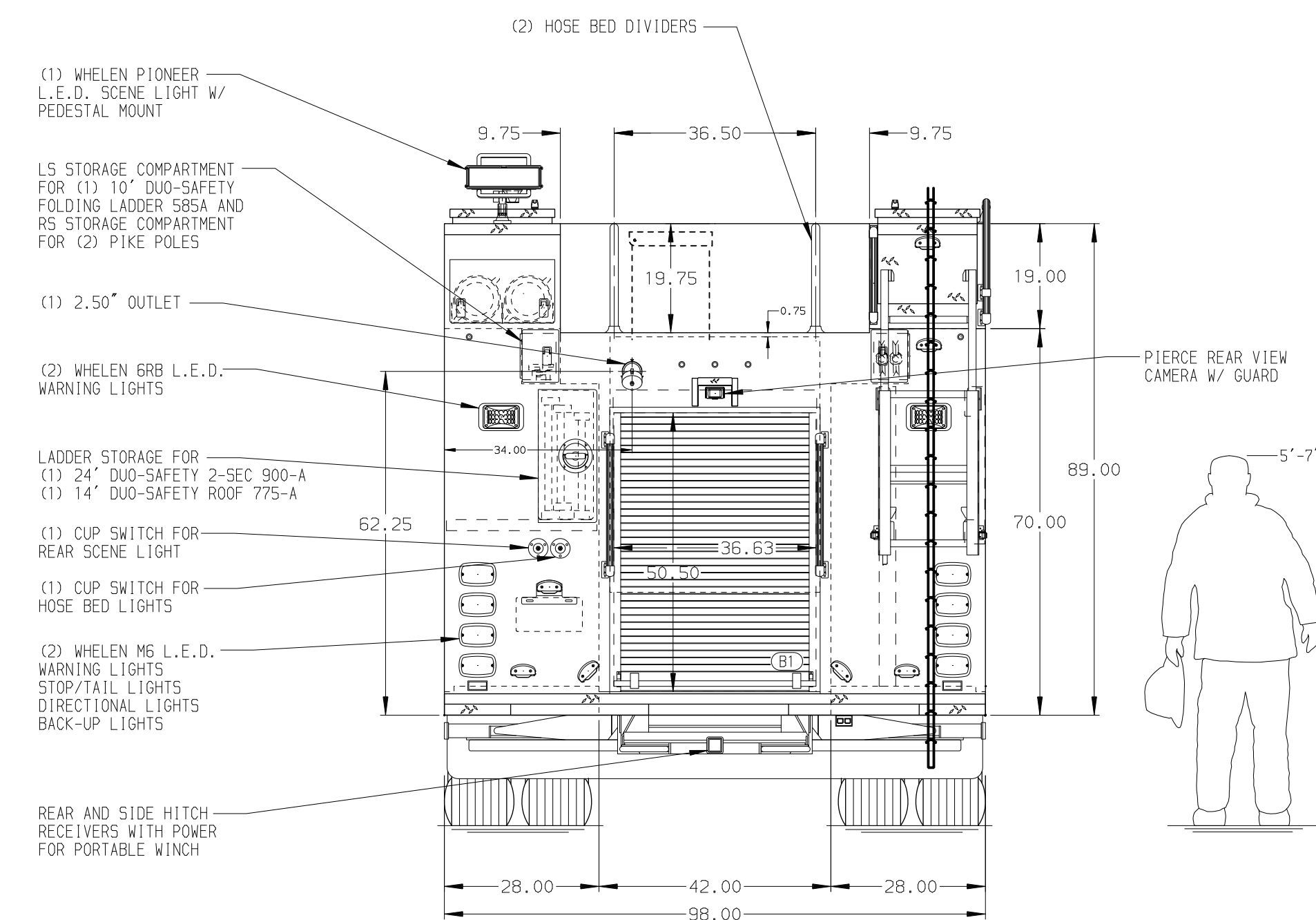

**NOTE**  
DIMENSIONS SHOWN ARE APPROXIMATE AND ARE SUBJECT TO MINOR DEVIATIONS AS MAY OCCUR OR BE NECESSARY IN CONSTRUCTION. MINOR DETAILS NOT SHOWN.

- SHORELINE RECEPTACLE LOCATED IN DRIVER'S STEP WELL
- AIR INLET/OUTLET WITH DISCONNECT COUPLING LOCATED ON DRIVER SIDE PUMP PANEL
- BATTERY CHARGER LOCATED IN LEFT SIDE HATCH COMPARTMENT
- BATTERY CHARGE INDICATOR LOCATED IN DRIVER'S STEP WELL
- SIX ADJUSTABLE SHELVES LOCATED PER SHOP ORDER
- FOUR FLOOR MOUNTED SLIDE-OUT TRAY LOCATED PER SHOP ORDER
- TWO TILTING/SLIDE-OUT TRAYS LOCATED PER SHOP ORDER
- ONE SLIDE-OUT TOOLBOARD LOCATED PER SHOP ORDER
- ALUMINUM PEGBOARD LOCATED PER SHOP ORDER
- WHELEN HOWLER SPEAKER SYSTEM LOCATED PER SHOP ORDER

## CUSTOMER APPROVAL

|              |          |
|--------------|----------|
| APPROVED BY: | DATE:    |
| CHASSIS DATA | TITLE    |
| MAKE         | FOR      |
| PIERCE       | DWG NO.  |
| MODEL        | ENFORCER |
| REV          | DATE     |
| BY           | CH       |



Pierce PUC Pumper Approval Drawing  
Sanford Fire Department  
37661AD

|            |            |
|------------|------------|
| JOB NO.    | 37661      |
| SCALE      | DATE       |
| 1:24       | 08MAR22    |
| DRAWN BY   | CHECKED BY |
| MMF        | COL        |
| SHEET SIZE | SHEET NO.  |
| D          | 1 OF 1     |