

- HOSEBED CAPACITIES
- ① 1000' OF 5.00" D.J. POLY HOSE
 - ② 500' OF 2.50" D.J. POLY HOSE
 - ③ 250' OF 2.50" D.J. POLY HOSE
 - ④ 300' OF 1.75" D.J. POLY HOSE

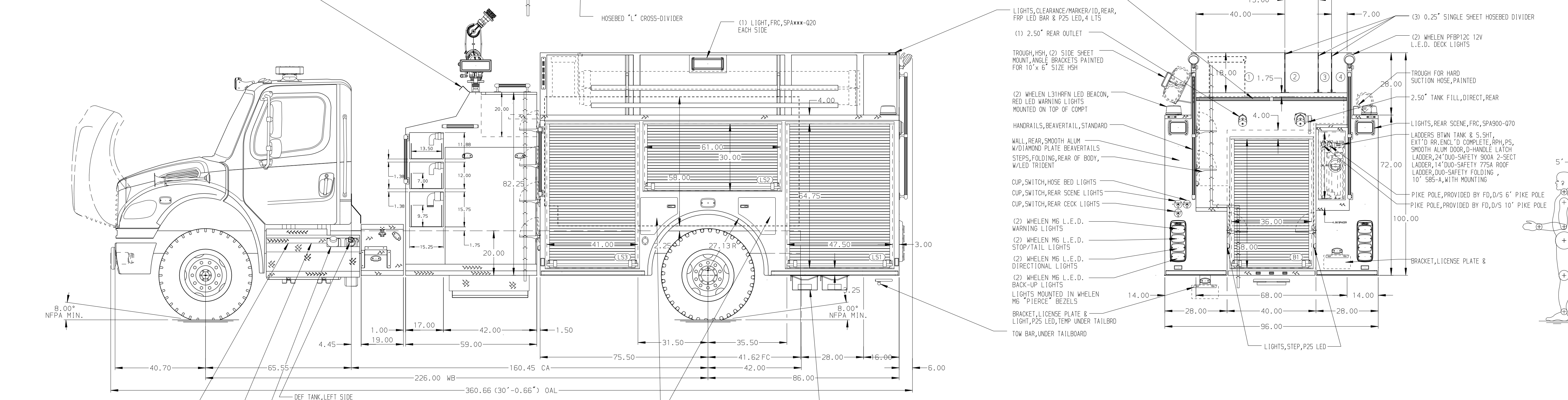

ALUMINUM BODY

NOTE
DIMENSIONS SHOWN ARE APPROXIMATE AND ARE SUBJECT TO MINOR DEVIATIONS AS MAY OCCUR OR BE NECESSARY IN CONSTRUCTION. MINOR DETAILS NOT SHOWN.

		JOB NO.	37811
		SCALE	DATE
MANUFACTURING INC. BRADENTON, FLORIDA		DRAWN BY	RHU
TITLE 1250-D-1250 WATER, 161" BDY, LS/RS FULL HGT FDLER 42" TOP MOUNT, 19" WALKWAY (2) 1.5" (1) 2.5" S/LAYS		CHECKED BY	RWI
FOR SENECA CASTLE FIRE DISTRICT SENECA CASTLE, NY		SHEET NO.	1 OF 1
DWG NO.		37811AD	

REV	DATE	BY	CH	CHASSIS DATA
09DEC22	JLA	NAS	MAKE	M2-106
20OCT22	JLA	NAS	FL	
16AUG22	RHU	RWI	MODEL	