

SURFACE DESIGNATION AND PATHWAY MARKINGS

BODY	WATER TANK
107' ASL Aluminum Body PUC	475 Gallon Poly Water Tank
COMPT, LEFT SIDE FRONT	Foam System
Full Height RollUp Forward	Husky 3 Single Agent Foam System
COMPT, LEFT SIDE REAR	Foam Cell
Full Height RollUp Rearward	25 Gallon Foam Cell, Reduced Water, PUC
COMPT, RIGHT SIDE FRONT	
Full Height RollUp Forward	
COMPT, RIGHT SIDE REAR	
Full Height RollUp Rearward	

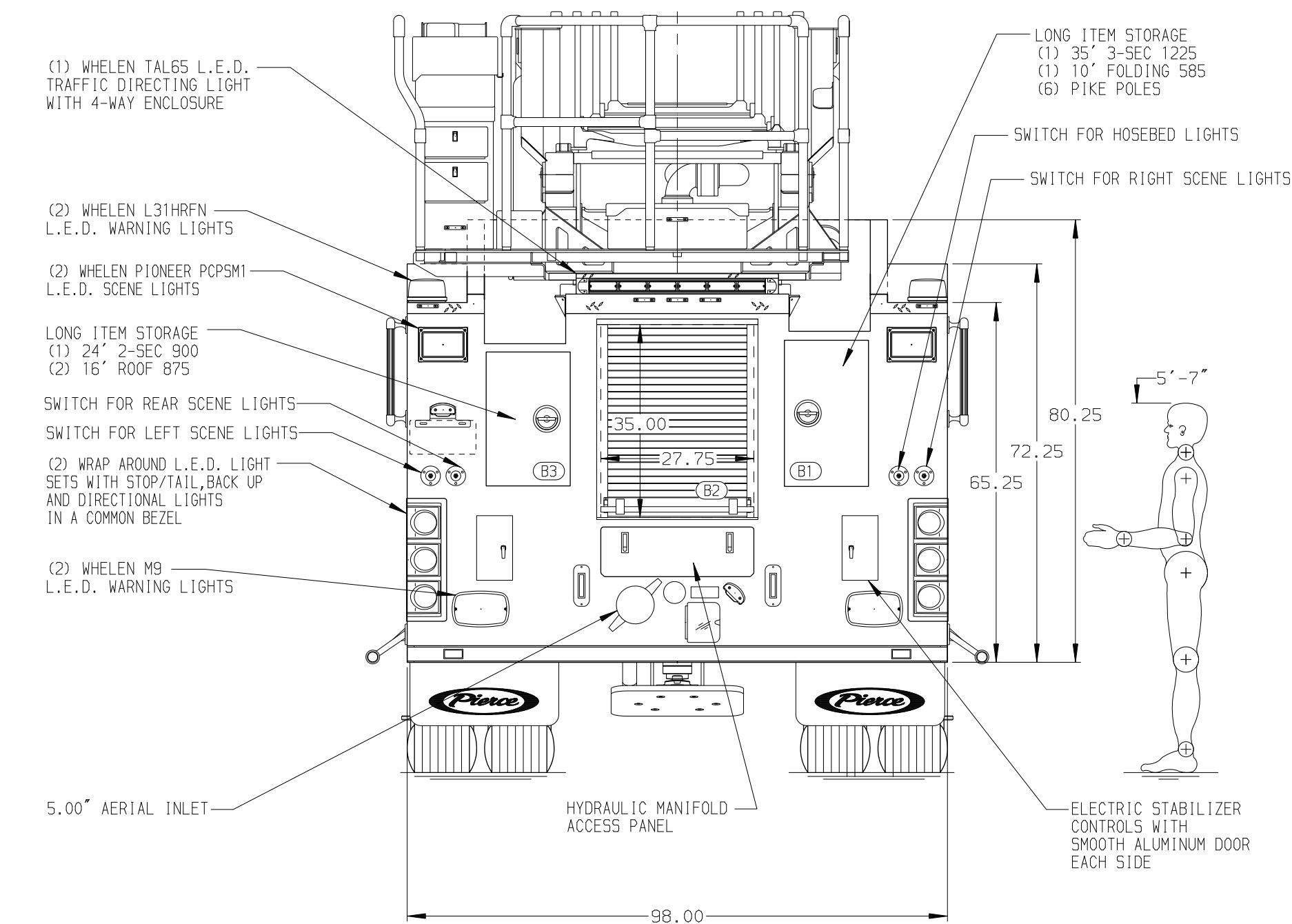
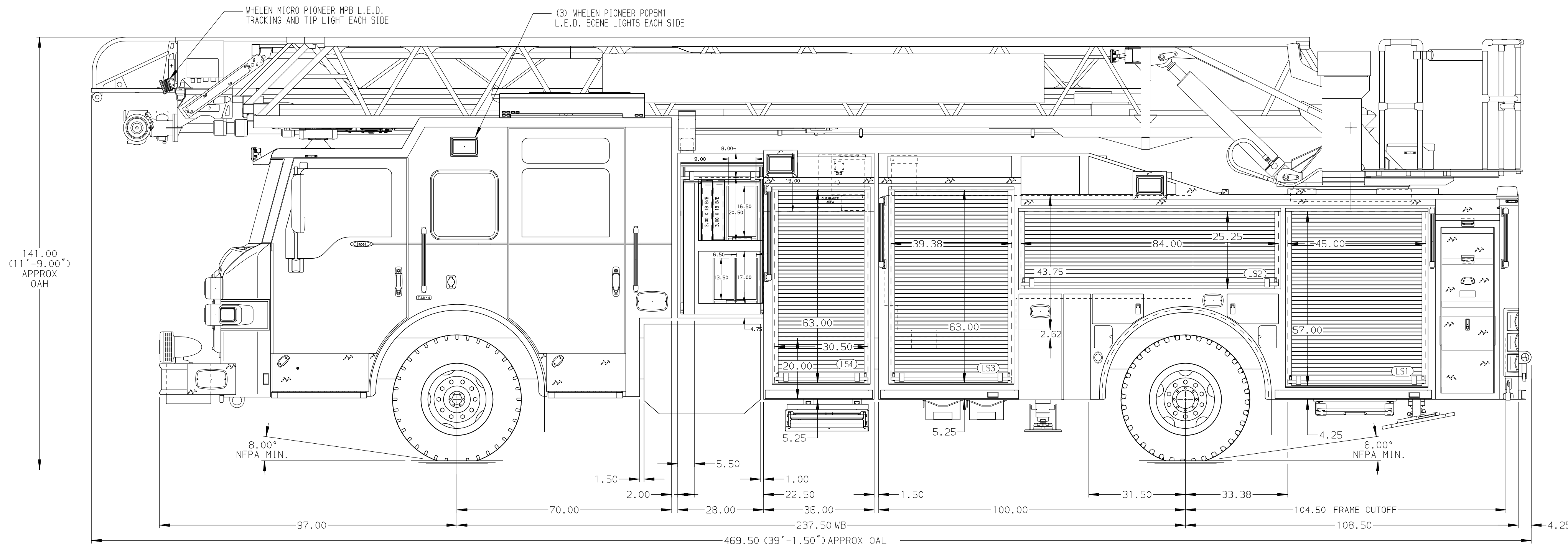

CHASSIS Impel Chassis, PUC ENGINE 450 HP Cummins L9 Engine	CAB 7010 Notched Impel FR Cab, PUC BUMPER 19\" Stainless Steel	AXLE, FRONT, CUSTOM 22,800 Lb TAK-4 Axle AXLE, REAR 33,500 Lb Meritor Axle	TRANSMISSION Allison 6th Gen, 3000 EV5 P	PUMPHOUSE Control Zone, PAL/PAP PUC PUMP 1500 GPM Pierce PUC	CROSSLAYS, 1.50" (2) 1.50", Poly Trays, 200' CROSSLAYS, 2.50" (1) 2.50", Poly Tray, 200'	SPEEDLAYS GENERATOR Mounting Honda Gas Generator CIF	SAFETY Frontal Impact Protection	CUSTOMER APPROVAL APPROVED BY: _____ DATE: _____		JOB NO. 37942	SCALE 1:24	DATE
NOTE DIMENSIONS SHOWN ARE APPROXIMATE AND ARE SUBJECT TO MINOR DEVIATIONS AS MAY OCCUR OR BE NECESSARY IN CONSTRUCTION. MINOR DETAILS NOT SHOWN.	1. NO LIMITED RETRACTION REQUIRED 2. ONE 1.50 OUTLET WITH 2.00 PIPING AND SWIVEL LOCATED ON TOP LEFT BUMPER 3. SHORELINE RECEPTACLE WITH KUSSMALL SUPER AUTO-EJECT LOCATED ON DRIVER SIDE OF THE CAB 4. AIR INLET WITH DISCONNECT COUPLING IN THE DRIVER SIDE STEPWELL 5. BATTERY CHARGER LOCATED PER ORDER 6. BATTERY CHARGE INDICATOR LOCATED NEAR DRIVER SEAT RISER WITH BRACKET 7. EIGHT ADJUSTABLE SHIELDS LOCATED PER ORDER 8. FOUR FLOOR MOUNTED SLIDE-OUT TRAYS LOCATED PER ORDER 9. NON-RAISED AERIAL PEDESTAL 10. LIFTING EYE ROPE RESCUE ATTACHMENT AT AERIAL TIP	11. 1500 GPM HIGH FLOW WATERWAY 12. AIR OUTLET WITH SHUT OFF VALVE ON PUMP PANEL 13. TWO SWING-OUT TOOLBOARDS PER ORDER 14. CIRCUIT BREAKER PANEL PER ORDER 15. RUNG LIGHTING ON AERIAL LADDER PER ORDER								TITLE 107' ASCENDANT AERIAL LADDER AND BODY ASSEMBLY FOR KEY WEST FIRE DEPARTMENT KEY WEST, FL DWG NO. 37942AD	DRAWN BY LWE	05DEC22
REV	DATE	BY	CH	IMPEL						SHEET SIZE D	SHEET NO. 1 OF 1	