

BODY 100' Ascendant Aerial Tower Alum Body COMPT, LEFT SIDE Full Height Lap Doors COMPT, RIGHT SIDE Full Height Lap Doors	WATER TANK 300 Gal/Lon Poly Water Tank Foam System Foam System Not Required Foam Cell Foam Cell Not Required
-------------------------------------------------------------------------------------------------------------------------------------------------	------------------------------------------------------------------------------------------------------------------------------------

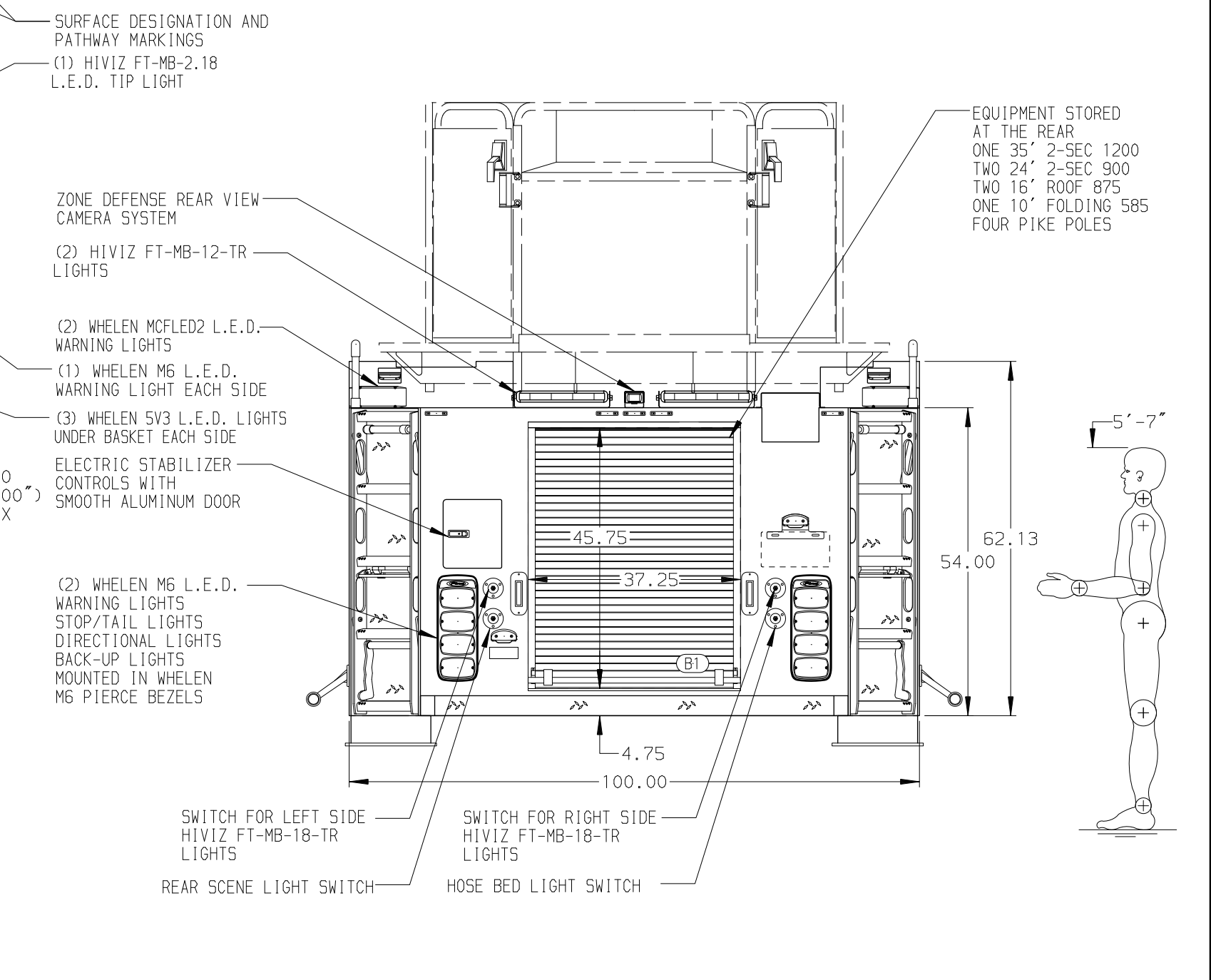
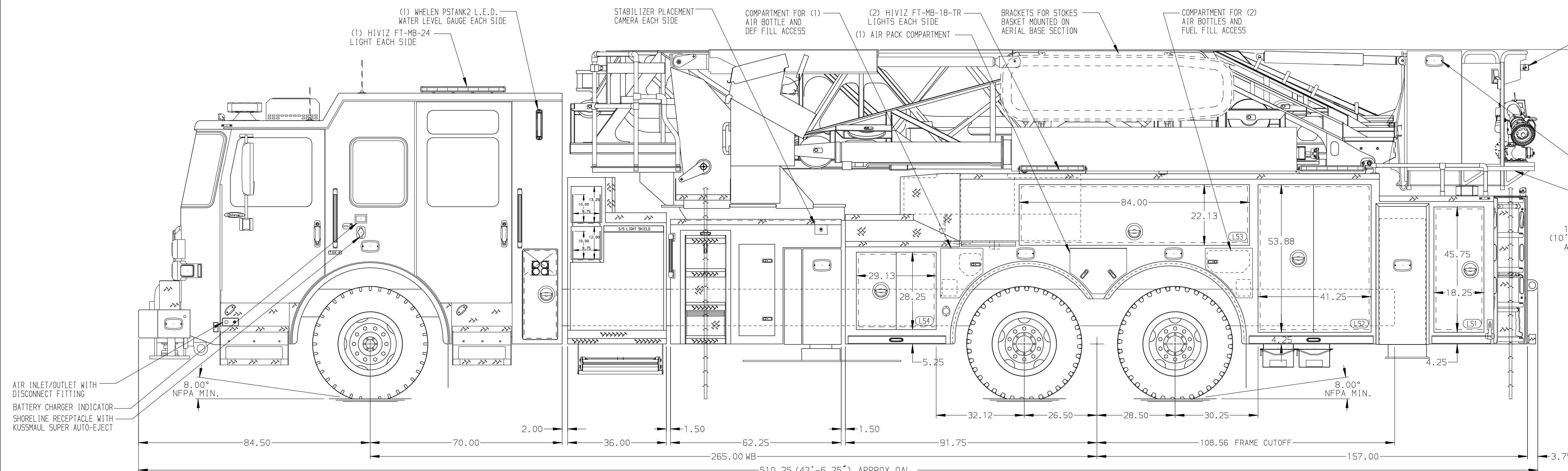

CHASSIS Enforcer Chassis ENGINE 605 HP Cummins X15 Engine	CAB 7010 Enforcer Cab BUMPER 15\"/>
----------------------------------------------------------------------------------	------------------------------------------------------------

AXLE, FRONT, CUSTOM 24,000 Lb TAK-4 Axle AXLE, REAR 54,000 Lb Meritor Axle	TRANSMISSION Allison 6th Gen, 4000 EV5 P	PUMPHOUSE 36\"/>
---------------------------------------------------------------------------------------------------	----------------------------------------------------	----------------------------

NOTE DIMENSIONS SHOWN ARE APPROXIMATE AND ARE SUBJECT TO MINOR DEVIATIONS AS MAY OCCUR OR BE NECESSARY IN CONSTRUCTION. MINOR DETAILS NOT SHOWN.	1. BATTERY CHARGER LOCATED BEHIND DRIVER'S SEAT 2. L.E.D. LIGHT STRIPS WITH STAINLESS STEEL PROTECTIVE COVER LOCATED IN HOSE BED 3. THREE ADJUSTABLE FULL WIDTH/FULL DEPTH SHELVES IN COMPARTMENT PER ORDER 4. ONE ADJUSTABLE TILTING SLIDE-OUT TRAYS IN COMPARTMENT PER ORDER 5. FOUR FLOOR MOUNTED SLIDE-OUT TRAYS IN COMPARTMENT PER ORDER 6. TWO 14.25\"/>
------------------------------------------------------------------------------------------------------------------------------------------------------------	-------------------------------------------------------------------------------------------------------------------------------------------------------------------------------------------------------------------------------------------------------------------------------------------------------------------------------------------------------------------------------

SAFETY Side Roll and Frontal Impact Protection	SPEEDLAYS Speedlays Not Required GENERATOR Generator Not Required	CROSSLAYS, 1.50\" (2) 1.50\", With Trays, 200' CROSSLAYS, 2.50\" 2.50\" Crosslays Not Required	CHASSIS DATA MAKE PIERCE MODEL ENFORCER	TITLE 100' ASCENDANT AERIAL PLATFORM AND BODY ASSEMBLY FOR CENTEREA CENTEREA, NY DWG NO. 37952AD	JOB NO. 37952 SCALE 1:24 DATE 18MAR22 CHECKED BY ZCH 21MAR22 SHEET SIZE D SHEET NO. 1 OF 1
----------------------------------------------------------	------------------------------------------------------------------------------------------	-----------------------------------------------------------------------------------------------------------------------	------------------------------------------------------------	-----------------------------------------------------------------------------------------------------------------------------------------	--------------------------------------------------------------------------------------------------------------------------------------------------------------------------