

PASSENGER'S SIDE COMPARTMENTS CONTAIN THE FOLLOWING:

- COMPARTMENT P1 CONTAINS:**
 - (1) FLOOR MOUNTED TRAY
 - (1) STD DEPTH ADJ SHELF
- COMPARTMENT P2 CONTAINS:**
 - (1) VERTICAL COMPARTMENT DIVIDER
 - (1) CIRCUIT BREAKER PANEL
 - (1) NIGHT SCAN CONTROLLER
 - (1) GENERATOR METER PANEL
 - (1) STD DEPTH ADJ SLIDE OUT/TILT TRAY
- COMPARTMENT P3 CONTAINS:**
 - (1) 1/2 DEPTH ADJ SHELF
 - (1) FLOOR MOUNTED TRAY
 - (1) 1/2 DEPTH ADJ SLIDE OUT TRAY
 - (4) POLY TOOL BOXES
- COMPARTMENT P4 CONTAINS:**
 - (1) 1/2 DEPTH ADJ SLIDE OUT/TILT TRAY
 - (1) FLOOR MOUNTED TRAY
 - (1) CAB LIFT CONTROLLER
 - (2) 2-WAY ADJ SLIDE OUT TRAYS

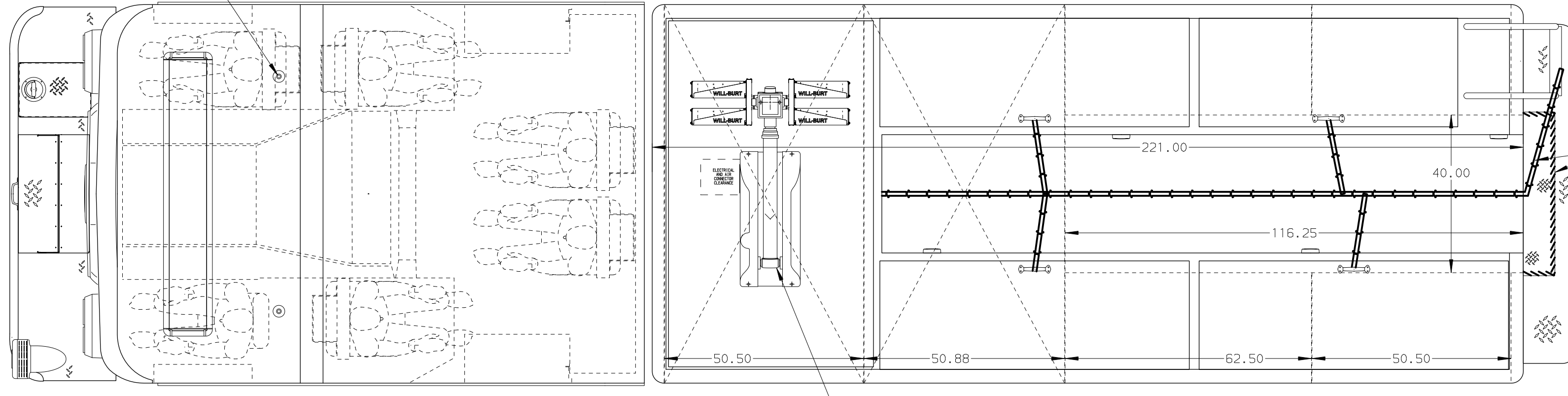
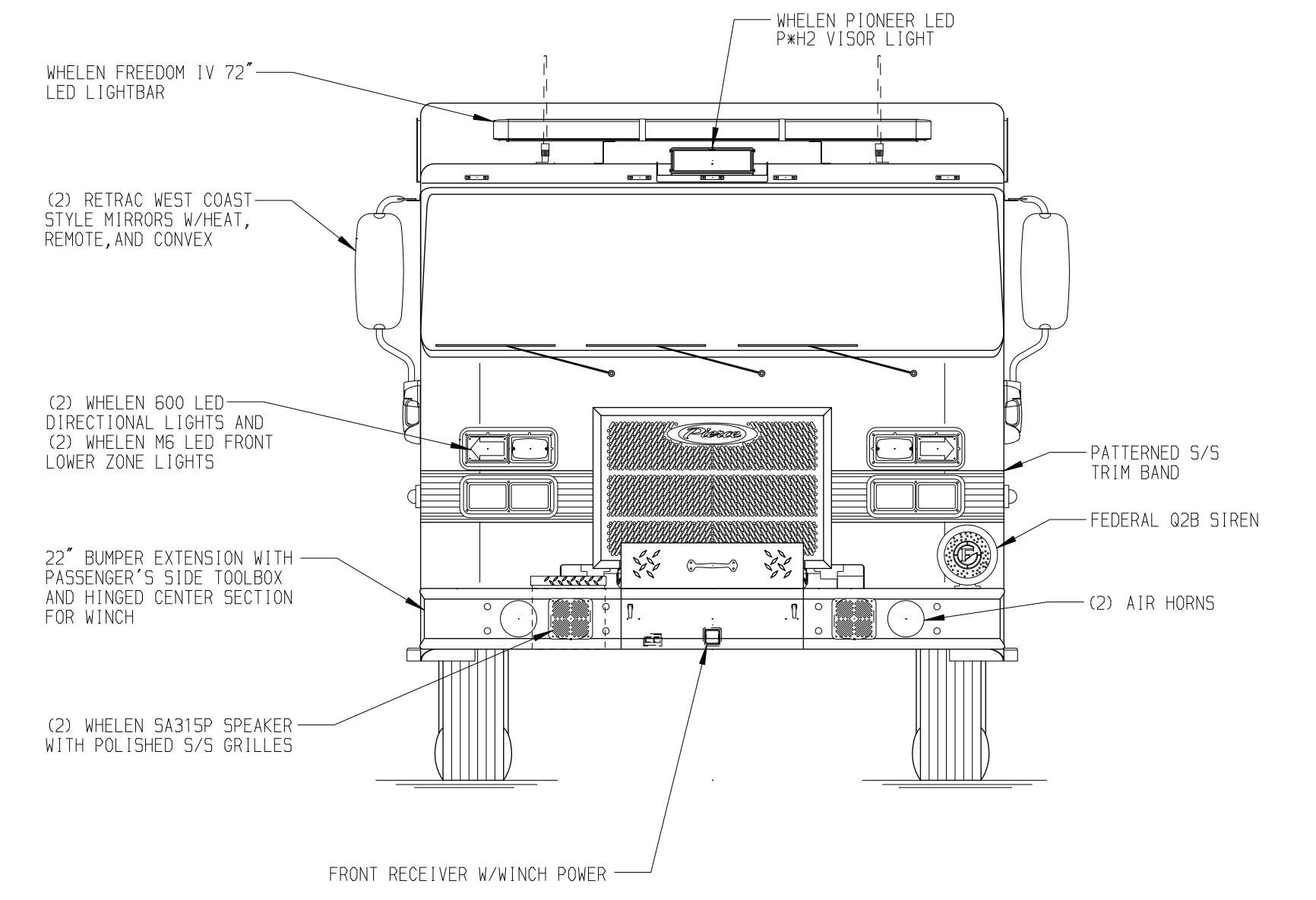
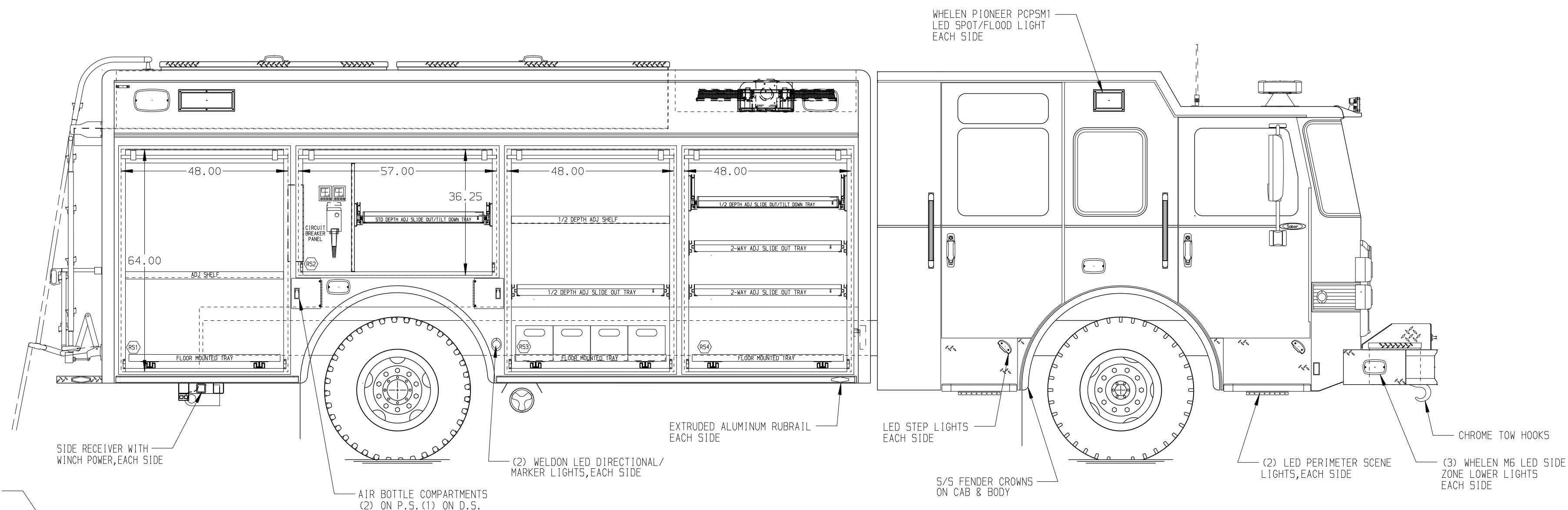

REAR COMPARTMENT CONTAINS THE FOLLOWING:

- COMPARTMENT R1 CONTAINS:**
 - (1) 110" DP SLIDE OUT TRAY
 - (1) FLOOR MOUNTED TRAY
 - (1) STOKES BASKET RACK

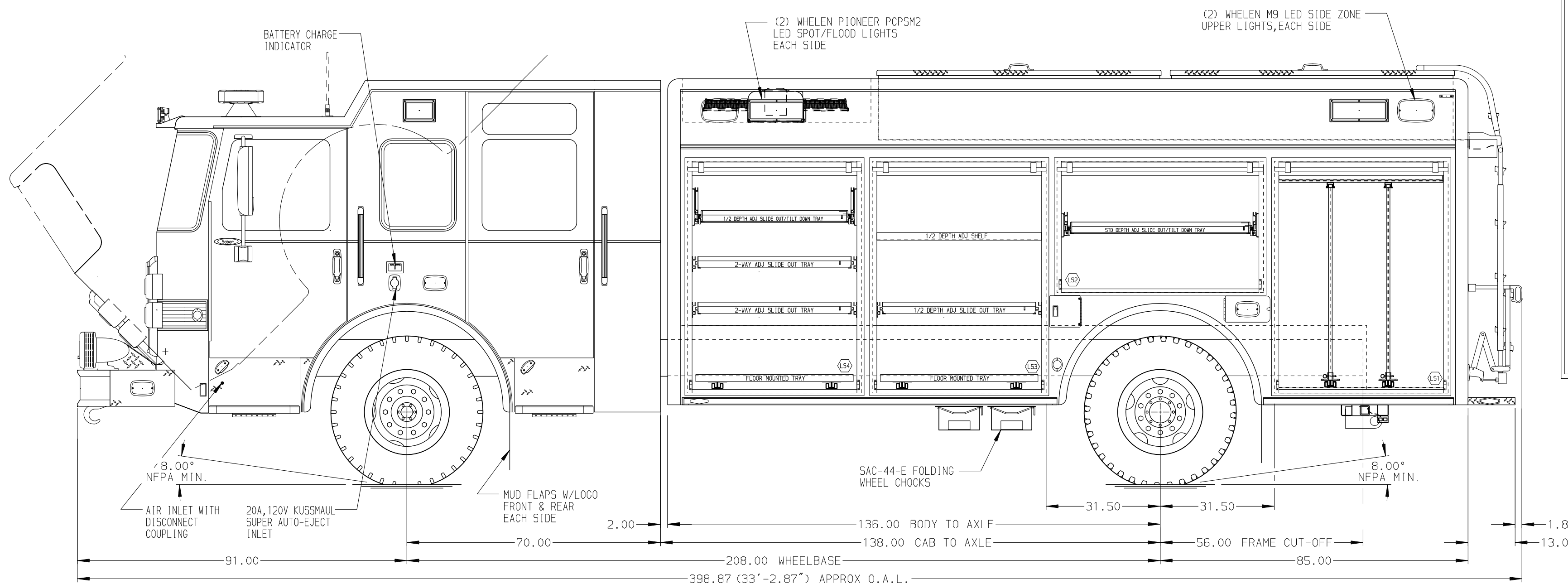

DRIVER'S SIDE COMPARTMENTS CONTAIN THE FOLLOWING:

- COMPARTMENT D1 CONTAINS:**
 - (2) STD DEPTH ADJ SLIDE OUT TOOLBOARDS
- COMPARTMENT D2 CONTAINS:**
 - (1) STD DEPTH ADJ SLIDE OUT/TILT TRAY
- COMPARTMENT D3 CONTAINS:**
 - (1) 1/2 DEPTH ADJ SHELF
 - (1) 1/2 DEPTH ADJ SLIDE OUT TRAY
 - (1) FLOOR MOUNTED TRAY
- COMPARTMENT D4 CONTAINS:**
 - (1) 1/2 DEPTH ADJ SLIDE OUT/TILT TRAY
 - (2) 2-WAY ADJ SLIDE OUT TRAYS
 - (1) FLOOR MOUNTED TRAY

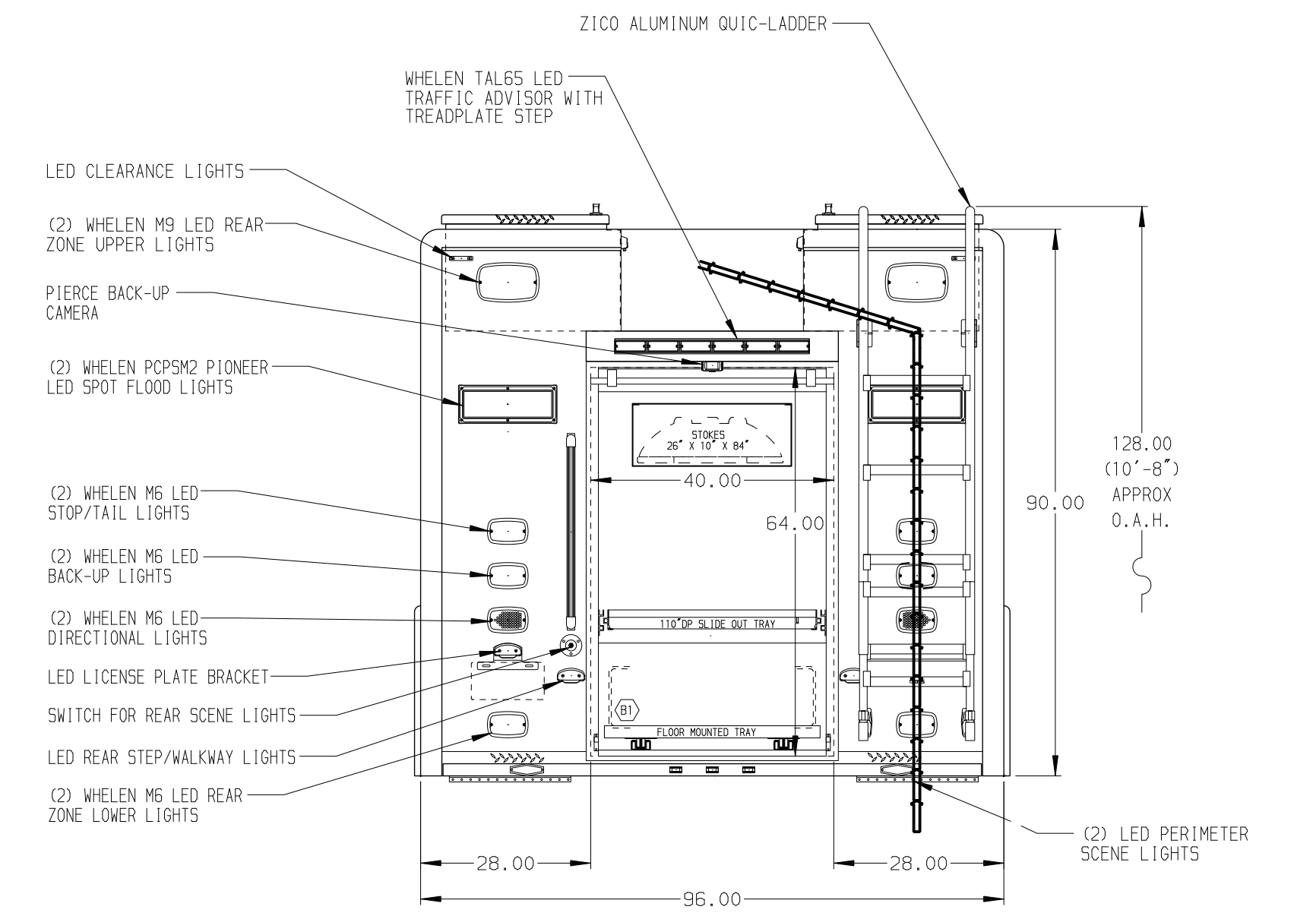

NOTE
 DIMENSIONS SHOWN ARE APPROXIMATE AND ARE SUBJECT TO MINOR DEVIATIONS AS MAY OCCUR OR BE NECESSARY IN CONSTRUCTION. MINOR DETAILS NOT SHOWN.

- NOTES:**
1. WARN #9,000 PORTABLE WINCH
 2. FLOOR IN CAB AND CREW CAB TO BE PADDED RUBBER
 3. PULL STRAPS ON ALL BODY ROLL UP DOORS
 4. PIERCE LED LIGHT STRIPS IN ALL BODY AND HATCH COMPARTMENTS
 5. 107A 75 AMP BATTERY CHARGER LOCATED BEHIND THE DRIVER'S SEAT
 6. S/S GUARDS ON ALL BODY ROLL-UP DOORS

(SIDE ROLL & FRONTAL IMPACT PROTECTION)

CLEAR DOOR WIDTH KEY

| | |
|---------------------------|---------|
| AMOR ROLL UP DOORS: | -2 1/4" |
| CORTITE ROLL UP DOORS: | -2 1/2" |
| PIERCE DOUBLE LIP DOORS: | -4 1/4" |
| PIERCE LIFT-UP LIP DOORS: | -1 1/2" |

(EX: 60" F-F - 2 1/4" = 57 3/4" CLEAR)
 (F-F) = FRAME TO FRAME

CUSTOMER APPROVAL

APPROVED BY: _____
 DATE: _____

| | | | |
|-----|------|----|----|
| REV | DATE | BY | CH |
| | | | |

| | | | | | |
|------|--|-------|------------------------------|------------|--------|
| | | TITLE | HEAVY DUTY RESCUE NON-WALKIN | JOB NO. | 38038 |
| | | FOR | PIERCE STOCK | SCALE | 1:24 |
| DATE | | | | DATE | |
| | | | | DRAWN BY | DHE |
| | | | | CHECKED BY | THS |
| | | | | DATE | 3MAY22 |
| | | | | SHEET SIZE | D |
| | | | | SHEET NO. | 1 OF 1 |

DWG NO. 38038AD