

- HOSEBED CAPACITIES
- ① 200' OF 1.75" D.J. HOSE
 - ② 200' OF 1.50" FORESTRY HOSE
 - ③ 500' OF 4.00" D.J. HOSE
 - ④ 500' OF 4.00" D.J. HOSE
 - ⑤ 400' OF 2.50" D.J. HOSE

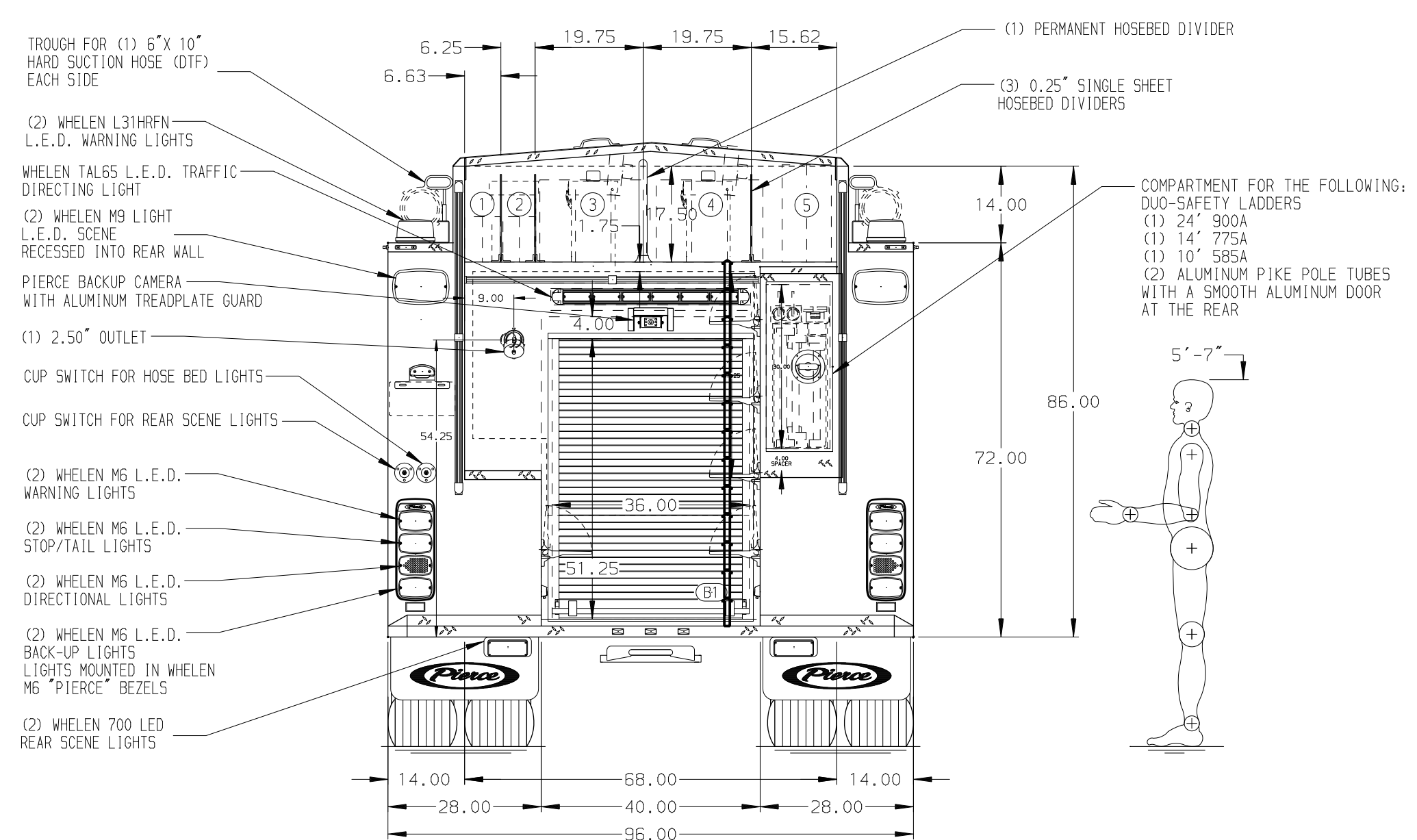
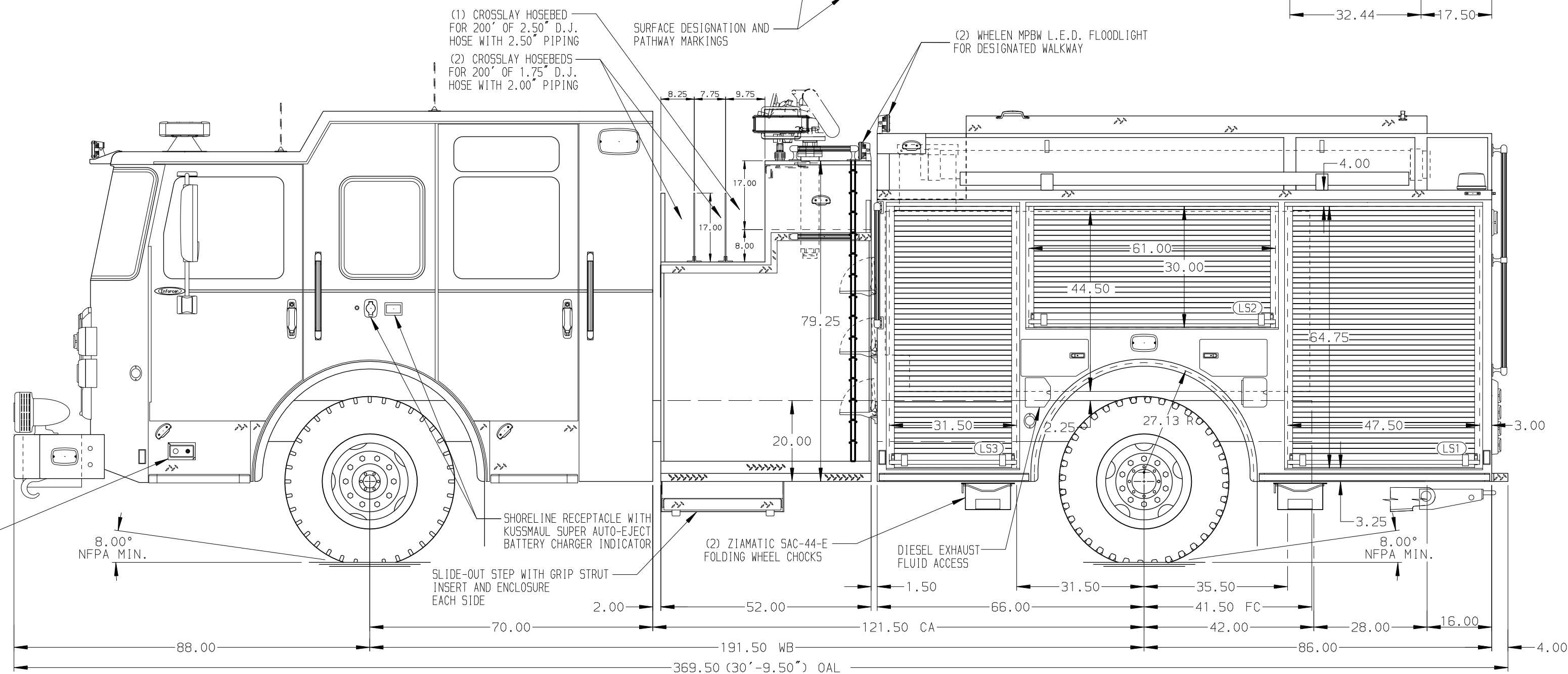

ALUMINUM BODY

NOTE
DIMENSIONS SHOWN ARE APPROXIMATE AND ARE SUBJECT TO MINOR DEVIATIONS AS MAY OCCUR OR BE NECESSARY IN CONSTRUCTION. MINOR DETAILS NOT SHOWN.

1. KUSSMAUL BATTERY CHARGER LOCATED BEHIND PASSENGER SEAT
2. DUAL L.E.D. LIGHT STRIPS LOCATED IN HOSE BED
3. SEVEN DRIP PAN GUARD FOR ROLL-UP DOOR LOCATED PER SHOP ORDER
4. FIVE FULL WIDTH/DEPTH ADJUSTABLE SHELF IN COMPARTMENT LOCATED PER SHOP ORDER
5. ONE ADJUSTABLE SLIDE-OUT TRAY IN COMPARTMENT LOCATED PER SHOP ORDER
6. SWING-OUT TOOL BOARD WITH PEGBOARD PATTERN IN COMPARTMENT LOCATED PER SHOP ORDER
7. PARTITION BETWEEN COMPARTMENTS L51/B1 AND R51/B1
8. ONE FLOOR MOUNTED SLIDE-OUT TRAY IN COMPARTMENT LOCATED PER SHOP ORDER
9. THREE ALUMINUM STORAGE BINS IN COMPARTMENT LOCATED PER SHOP ORDER
10. ONE TOOL MOUNTING TURNABLE (LAZY SUSAN) IN COMPARTMENT B1
11. ONSPOT AUTOMATIC TIRE CHAINS TO BE PROVIDED AT REAR
12. ONE 120 NEMA DUPLEX RECEPTICAL LOCATED PER SHOP ORDER

CUSTOMER APPROVAL

| | |
|--------------|---------|
| APPROVED BY: | |
| DATE: | |
| CHASSIS DATA | TITLE |
| MAKE | FOR |
| PIERCE | DWG NO. |
| MODEL | |
| ENFORCER | |



1500-D-750P W/20 & 30 GAL FOAM CELLS, 152" FH FDLER SIDE CONTROL (3) XLYAS, LADDERS BESIDE TANK, DELUGE ATTLEBORO FIRE DEPARTMENT ATTLEBORO, MASSACHUSETTS

38049AD

| | |
|------------|-----------|
| JOB NO. | 38049 |
| SCALE | DATE |
| 1:24 | |
| DRAWN BY | 05JAN23 |
| SDS | |
| CHECKED BY | 13JAN23 |
| PHA | |
| SHEET SIZE | SHEET NO. |
| D | 1 OF 1 |