

BODY 100' Ascendant Aerial Tower Alum Body COMPT, LEFT SIDE Full Height RollUp, Lift Up Doors COMPT, RIGHT SIDE Full Height RollUp, Lift Up Doors	WATER TANK 280 Gallon Poly Water Tank Foam System Husky 3 Single Agent Foam System Foam Cell 20 Gallon Foam Cell, Reduced Water
---	---

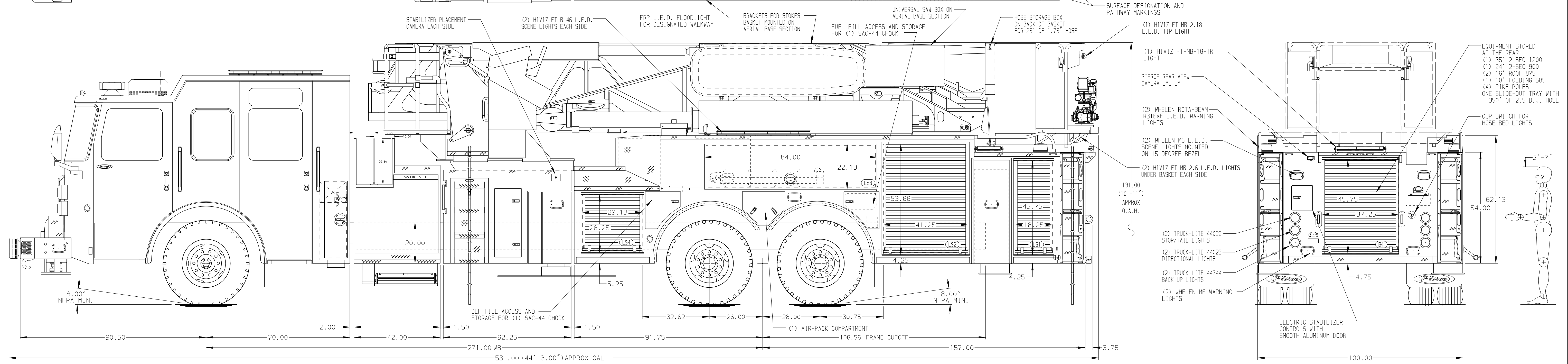

CHASSIS Enforcer Chassis ENGINE 605 HP Cummins X15 Engine	CAB 7010 Enforcer Cab BUMPER 21" Stainless Steel	AXLE, FRONT, CUSTOM 23,000 Lb Dana Axle AXLE, REAR 54,000 Lb Meritor Axle	TRANSMISSION Allison 6th Gen, 4500 EV5 P	PUMPHOUSE 42" Control Zone Side Mount PUMP 2000 GPM Waterous S100	CROSSLAYS, 1.50" (2) 1.50", 200" D.J. CROSSLAYS, 2.50" 2.50" Crosslay Not Required	SPEEDLAYS Speedlays Not Required GENERATOR Generator Not Required	-	CUSTOMER APPROVAL APPROVED BY: _____ DATE: _____	MANUFACTURING INC.	JOB NO. 38102 SCALE 1:24 DATE _____
NOTE DIMENSIONS SHOWN ARE APPROXIMATE AND ARE SUBJECT TO MINOR DEVIATIONS AS MAY OCCUR OR BE NECESSARY IN CONSTRUCTION. MINOR DETAILS NOT SHOWN.										
1. SHORELINE RECEPTACLE WITH KUSSMAUL SUPER AUTO-EJECT LOCATED IN DRIVER SIDE STEP WELL 2. AIR INLET WITH DISCONNECT COUPLING IN THE DRIVER SIDE STEPPED WELL 3. BATTERY CHARGER LOCATED PER ORDER 4. BATTERY CHARGE INDICATOR LOCATED ON THE DRIVER SIDE SEAT RISER 5. ONE PAIR OF WHEEL CHECKS LOCATED PER ORDER 6. NON-RAISED AERIAL PEDESTAL 7. 3-IN-1 LYFECOMBO BRACKETS AT AERIAL BASKET 8. EIGHT ADJ SHELVES PER ORDER 9. ONE SLIDE-OUT TRAY PER ORDER 10. TWO FLOOR MOUNTED SLIDE-OUT TRAYS PER ORDER			11. ONE TOOLBOARD ADDED TO SLIDE-OUT TRAY 12. TWO SLIDE-OUT TOOLBOARDS PER ORDER 13. ONE SWING-OUT TOOLBOARD PER ORDER 14. ONE VERTICAL PARTITION PER ORDER 15. PEGBOARD ON SIDE WALL PER ORDER 16. ONE LITTLE GIANT LADDER REVOLUTION MODEL 17 17. THREE 120V RECEPTACLES PER ORDER 18. RING LIGHTING ON AERIAL LADDER 19. DC POWER TO AERIAL TIP			TITLE 100' ASCENDANT AERIAL TOWER AND BODY ASSEMBLY MAKE PIERCE FOR KILBOURN VOLUNTEER FIRE DEPARTMENT KILBOURN, WI DWG NO. 38102AD SHEET NO. 1 OF 1				