

BODY 107' ASL Tandem Axle Aluminum Body COMPT, LEFT SIDE FRONT FH/FD RollUp Forward w/o Chute COMPT, LEFT SIDE REAR FH/FD RollUp and Lift-up Rearward COMPT, RIGHT SIDE FRONT FH/FD RollUp Forward w/o Chute COMPT, RIGHT SIDE REAR FH/FD RollUp and Lift-up Rearward	WATER TANK Not Required Foam System Not Required Foam Cell Not Required
---	---

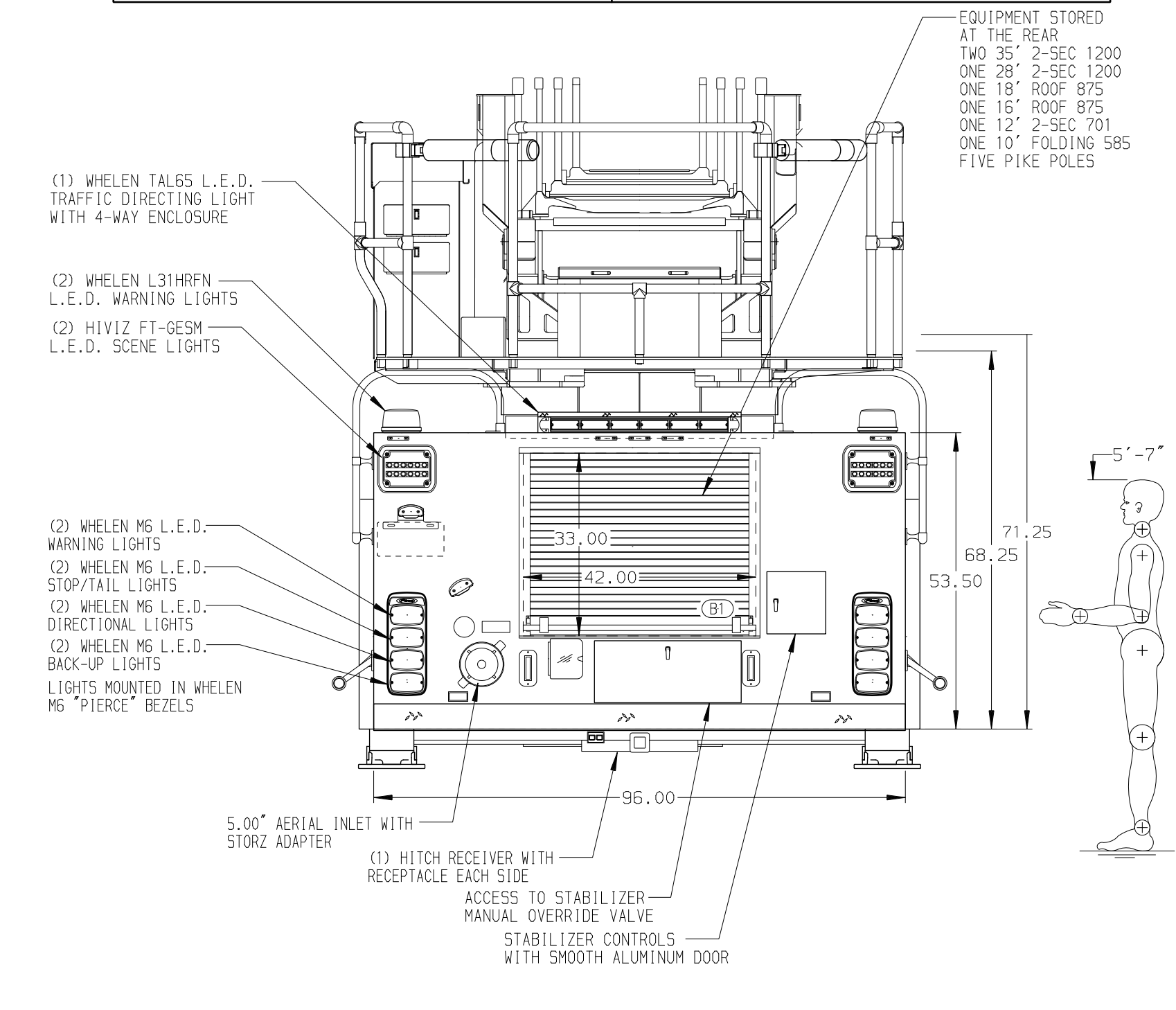
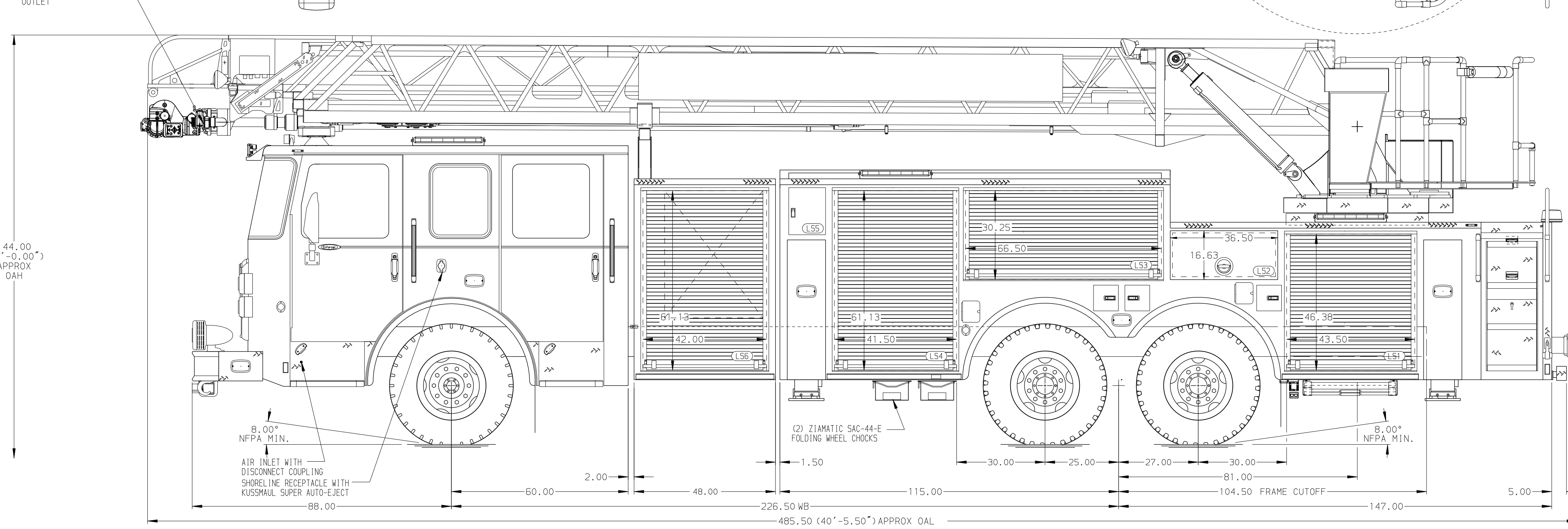

CHASSIS Enforcer Chassis ENGINE 500 HP Cummins X12 Engine	CAB 6000 Enforcer Cab BUMPER 19\" Extended Stainless Steel	AXLE, FRONT, CUSTOM 21,500 Lb Meritor Axle AXLE, REAR 44,000 Lb Meritor Axle	TRANSMISSION Allison 5th Gen, 4500 EV5 PR	PUMPHOUSE 48\" Compartment IPD Pump PUMP Not Required	CROSSLAYS, 1.50\" Crosslays Not Required CROSSLAYS, 2.50\" Crosslays Not Required	SPEEDLAYS Speedlays Not Required GENERATOR Generator Not Required	SAFETY Side Roll and Frontal Impact Protection	CUSTOMER APPROVAL APPROVED BY: _____ DATE: _____		JOB NO. 38175 01	SCALE 1:24	DATE
NOTE DIMENSIONS SHOWN ARE APPROXIMATE AND ARE SUBJECT TO MINOR DEVIATIONS AS MAY OCCUR OR BE NECESSARY IN CONSTRUCTION. MINOR DETAILS NOT SHOWN.	1. BATTERY CHARGER INDICATOR LOCATED ON DRIVER'S SEAT RISER 2. 2-WAY INTERCOM SYSTEM BETWEEN AERIAL TIP OR PLATFORM AND TURNTABLE 3. 120V POWER TO AERIAL TIP NOT REQUIRED 4. BREATHING AIR TO AERIAL BASKET NOT REQUIRED 5. AERIAL PEDESTAL RAISED 3.00\" 6. LIFTING EYE ROPE RESCUE ATTACHMENT AT AERIAL TIP 7. LIFEPUULLEY RESCUE SYSTEM AT AERIAL TIP 8. PAINTED STORAGE BOX FOR LIFE PULLEY ROPE TIE BAR AT AERIAL BASE SECTION 9. STABILIZER COMPARTMENTS MODIFIED FOR 18\" GROUND PENETRATION 10. STABILIZERS MODIFIED FOR 18\" GROUND PENETRATION	11. TRIDENT FOLDING STEPS ON AERIAL DEVICE 12. REMOTE LADDER CONTROLS AT AERIAL TIP 13. 1500 GPM HIGH FLOW WATERWAY						CHASSIS DATA		TITLE 107 ASCENDANT AERIAL LADDER & BODY ASSEMBLY	DRAWN BY JGA	07MAR22
								PIERCE	FOR CITY OF CALGARY CALGARY, AB	CHECKED BY JJR	09MAR22	
								MODEL	DWG NO. 38175AD-SH1	SHEET SIZE D	SHEET NO. 1 OF 2	