

**PUMPER  
BODY**

Medium Aluminum 2nd Gen Pumper

**CHASSIS**

Enforcer Chassis

**CHASSIS  
AXLE, FRONT, CUSTOM**

18,000 Lb Meritor Axle

**AXLE, REAR**

27,000 Lb Meritor Axle

**ENGINE**

400 HP Cummins L9 Engine

**TRANSMISSION**

Allison 6th Gen, 3000 EVS P

**BUMPER**

19" Extended Stainless Steel

**CAB**

6000 Enforcer Cab

**BODY  
WATER TANK**

750 Gallon Poly Water Tank  
COMPT, PUMPER, REAR

**COMPT, PUMPER, LEFT SIDE**

152" Lap Full Height Front & Rear FOLER

**COMPT, PUMPER, RIGHT SIDE**

152" Lap Low FOLER

**FIRE SUPPRESSION  
PUMPHOUSE**

48" Control Zone Side Mount

**PUMP**

1250 GPM Hale QFLO

**CROSSLAYS, 1.50"**

(2) 1.50" Standard Capacity

**CROSSLAYS, 2.50"**

2.50" Crosslay Not Required

**SPEEDLAYS**

Speedlays Not Required

**GENERATOR**

Generator Not Required

**Foam System**

Foam System Not Required

**Foam Cell**

30 Gal Foam Not Reduce

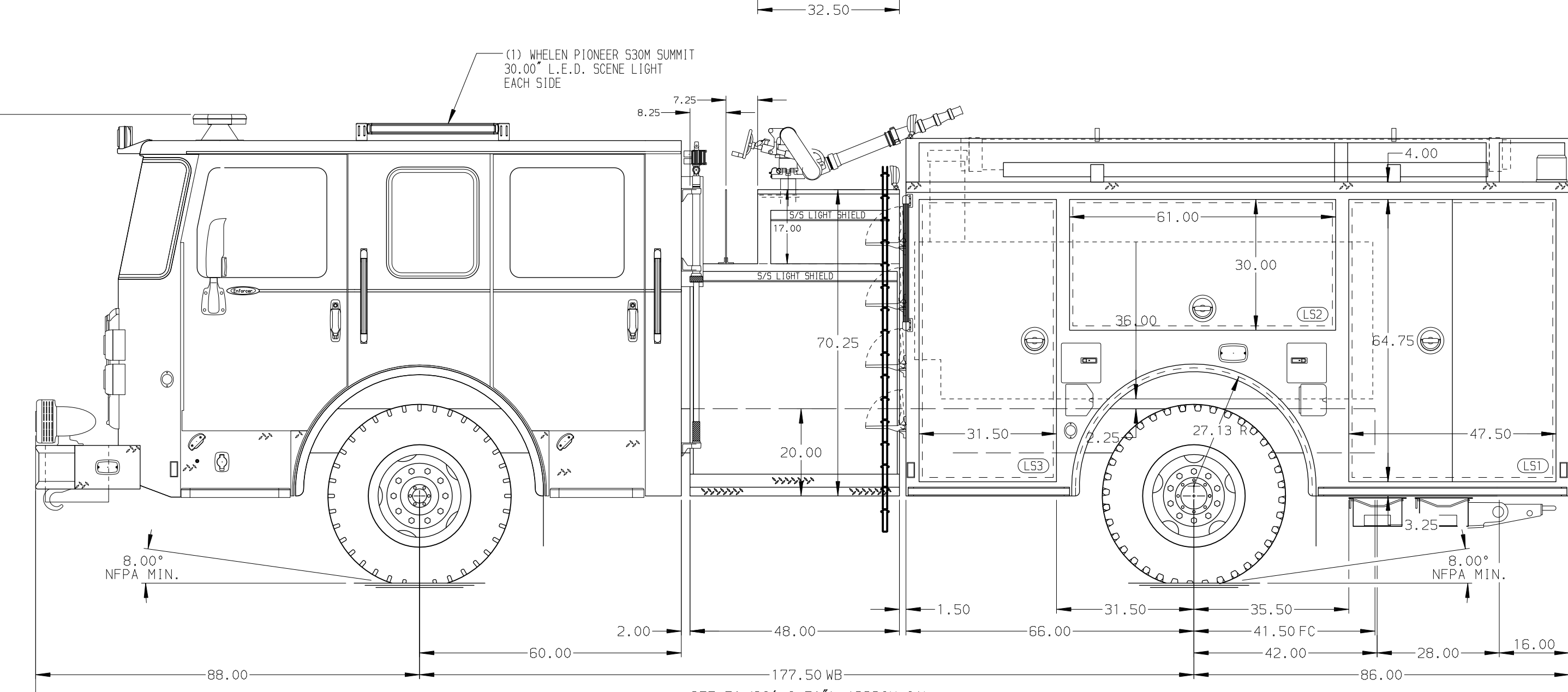
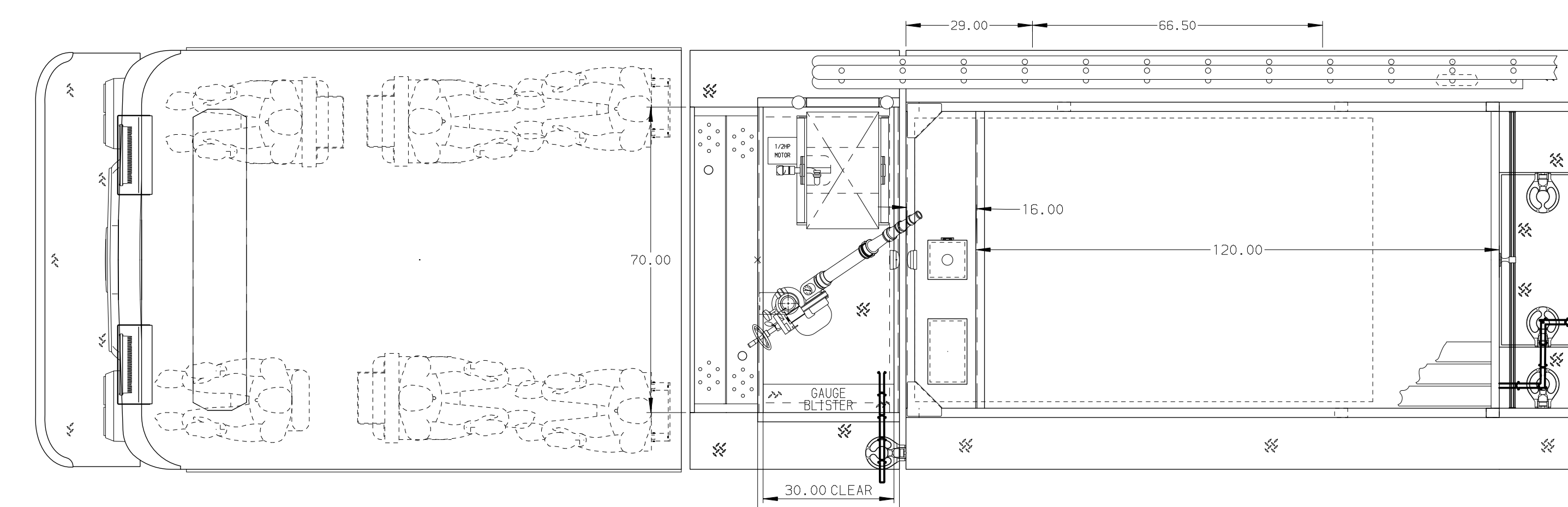
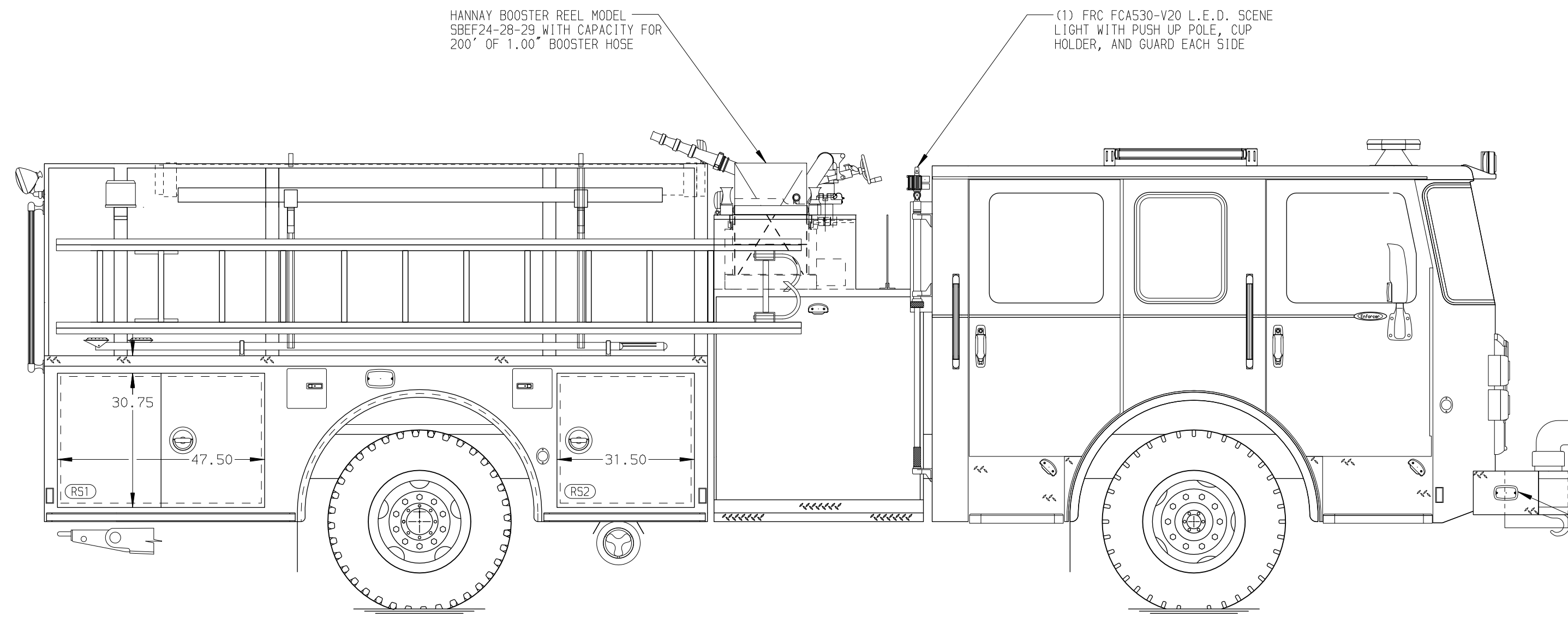

HOSEBED CAPACITY	
BED 1	1500' OF 4.00" D.J. POLY HOSE
BED 2	200' OF 2.50" D.J. POLY HOSE
BED 3	400' OF 1.75" D.J. POLY HOSE

**NOTE**  
DIMENSIONS SHOWN ARE APPROXIMATE AND ARE SUBJECT TO MINOR DEVIATIONS AS MAY OCCUR OR BE NECESSARY IN CONSTRUCTION. MINOR DETAILS NOT SHOWN.

- ONE 1.50 OUTLET WITH 2.00 PIPING AND SWIVEL LOCATED ON TOP BUMPER RIGHT SIDE
- SHORELINE RECEPTACLE WITH KISSMALL SUPER AUTO-EJECT LOCATED ON DRIVER SIDE STEPWELL
- AIR INLET WITH DISCONNECT COUPLING IN THE DRIVER SIDE STEPWELL
- BATTERY CHARGER LOCATED PER ORDER
- BATTERY CHARGE INDICATOR LOCATED ON THE DRIVER SIDE SEAT RISER
- SEVEN ADJUSTABLE SHELVES LOCATED PER ORDER
- ONE FLOOR MOUNTED SLIDE-OUT TRAY LOCATED PER ORDER
- ONE SWING-OUT TOOLBOARD LOCATED PER SHOP ORDER
- AUTOMATIC TIRE CHAINS

CUSTOMER APPROVAL			
APPROVED BY:			
DATE:			
REV	DATE	BY	CH
-	-	-	-

		JOB NO.	38465
TITLE Pierce Pumper Approval Drawing		SCALE	1:24
MAKE PIERCE		DATE	
FOR Auburn Fire Department		DRAWN BY	MMF
MODEL ENFORCER		CHECKED BY	COL
DWG NO. 38465AD		DATE	06JAN23
		SHEET SIZE	D
		SHEET NO.	1 OF 1