

HOSEBED CAPACITIES

- ① - 200' OF 2.50\"/>

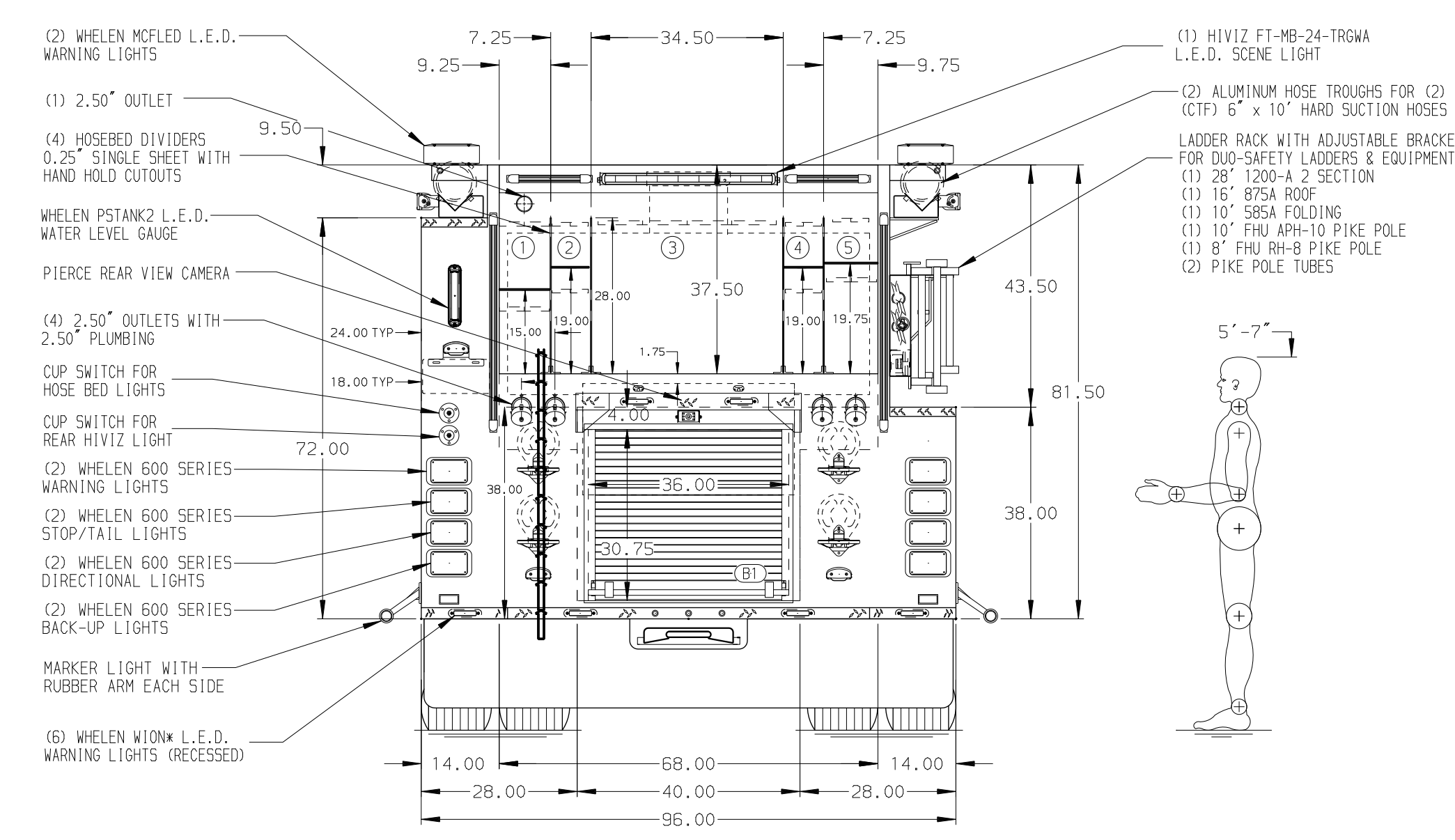
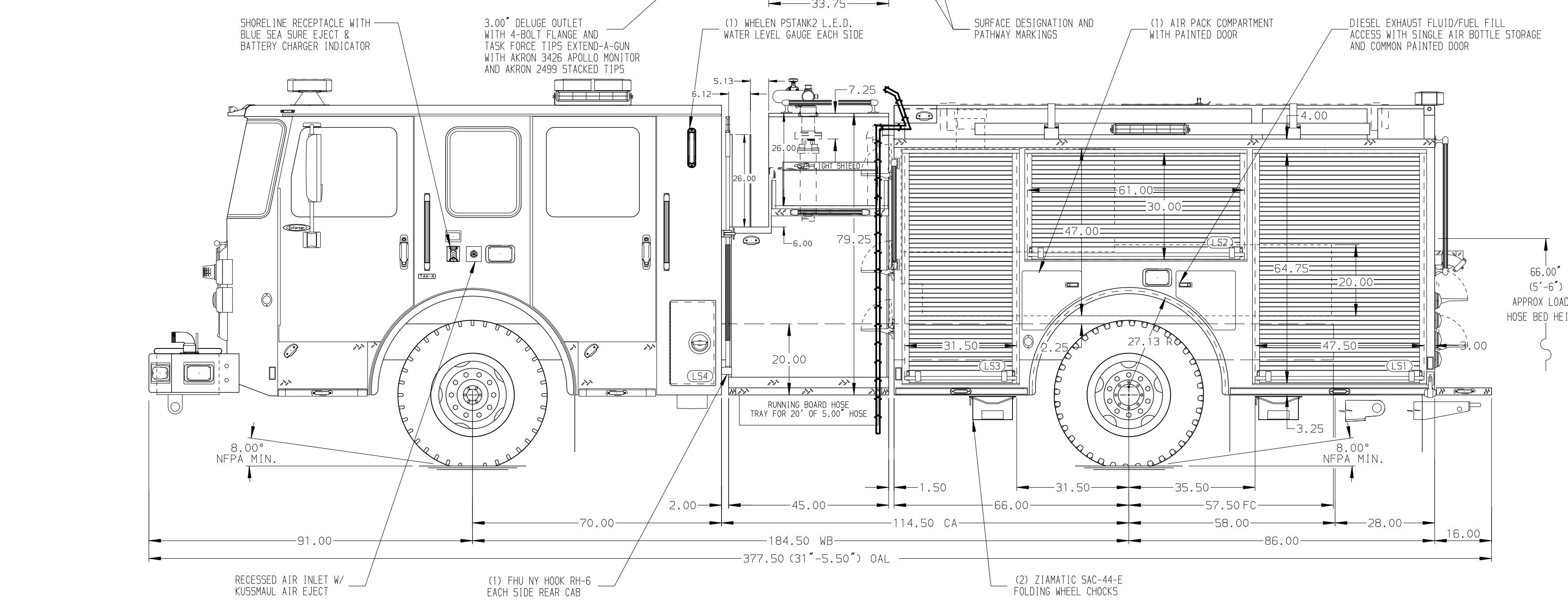

ALUMINUM BODY

SIDE ROLL AND FRONTAL IMPACT PROTECTION

NOTE
DIMENSIONS SHOWN ARE APPROXIMATE AND ARE SUBJECT TO MINOR DEVIATIONS AS MAY OCCUR OR BE NECESSARY IN CONSTRUCTION. MINOR DETAILS NOT SHOWN.

1. ONSPOT AUTOMATIC TIRE CHAINS TO BE PROVIDED AT REAR
2. ONE 120V RECEPTACLE LOCATED PER SHOP ORDER
3. ROSSO DV X24 DUAL FORWARD AND INTERIOR CAMERA MOUNTED INSIDE OF FRONT WINDSHIELD
4. BATTERY CHARGER LOCATED BEHIND THE DRIVER'S SEAT
5. DUAL L.E.D. LIGHT STRIPS LOCATED IN HOSE BED
6. DRIP PAN GUARD FOR ROLL-UP DOOR LOCATED PER SHOP ORDER
7. FOUR FULL WIDTH/DEPTH ADJUSTABLE SHELVES LOCATED PER SHOP ORDER
8. ONE FIXED FULL WIDTH/DEPTH SHELF LOCATED PER SHOP ORDER
9. ONE SWING-OUT ALUMINUM TOOL BOARD LOCATED PER SHOP ORDER
10. PARTITION BETWEEN COMPARTMENTS RS1/RS1
11. TWO VERTICAL PARTITIONS (SPECIAL HEIGHT) LOCATED PER SHOP ORDER
12. RETENTION NETTING LOCATED PER SHOP ORDER
13. ONE TOOL BOARD MOUNTED ON THE BACK WALL LOCATED PER SHOP ORDER
14. TWO 6-PLACE 120V DUPLEX RECEPTACLES LOCATED PER SHOP ORDER

REV	DATE	BY	CH	ENFORCER
07NOV23	JJB	JGO		PIERCE
29SEP23	JJB	JGO		MODEL

		JOB NO.	38469
		SCALE	DATE
CHASSIS DATA TITLE 2000-D-750P, 750 GAL WATER TANK, 152" FDLER PUMPER RS LADDER BRACKETS, (2) CROSSLAYS, DELUGE MAKE WESLEY CHAPEL VFD, INC MODEL WESLEY CHAPEL, NORTH CAROLINA DWG NO. 38469AD	FOR	DRAWN BY	JJB
	ENFORCER	CHECKED BY	CDU
		SHEET SIZE	SHEET NO.
		D	1 OF 1