

<p>BODY</p> <p>Aerial, HD Ladder 105', Alum Body</p> <p>COMPT, LEFT SIDE FRONT</p> <p>FH/FD RollUp Forward w/o Chute</p> <p>COMPT, LEFT SIDE REAR</p> <p>FH/FD RollUp and Lift-up Rearward</p> <p>COMPT, RIGHT SIDE FRONT</p> <p>Full Height RollUp Forward</p> <p>COMPT, RIGHT SIDE REAR</p> <p>Full Height RollUp and Liftup Rearward</p>	<p>WATER TANK</p> <p>480 Gallon PAL Notched Poly Water Tank</p> <p>Foam System</p> <p>Husky 3 Single Agent Foam System</p> <p>Foam Cell</p> <p>20 Gallon Foam Cell, Reduced Water</p>
--	--

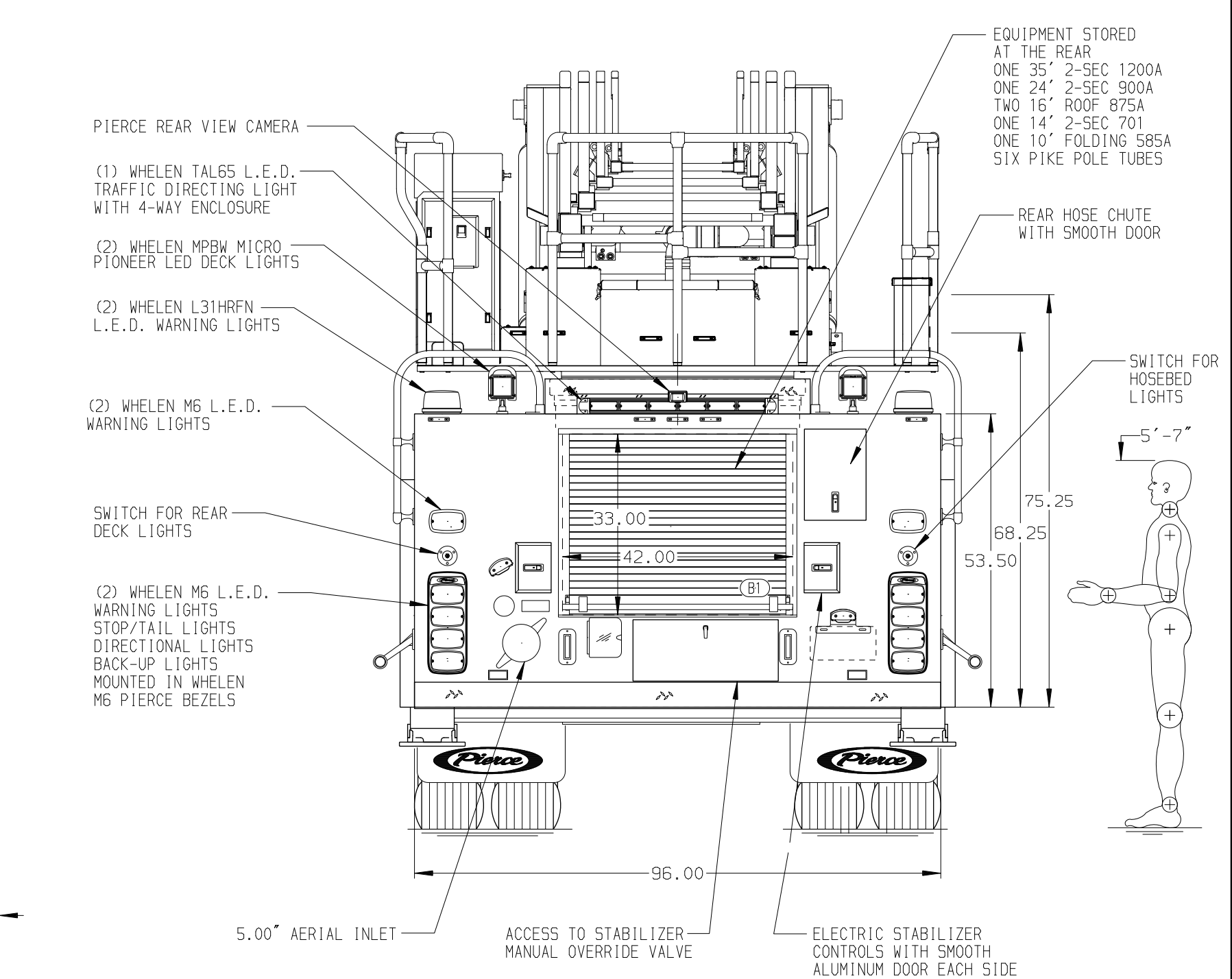

<p>CHASSIS</p> <p>Enforcer Chassis</p> <p>ENGINE</p> <p>500 HP Cummins X12 Engine</p>	<p>CAB</p> <p>7010 Notched Enforcer Cab</p> <p>BUMPER</p> <p>19" Extended Stainless Steel</p>	<p>AXLE, FRONT, CUSTOM</p> <p>22,800 Lb TAK-4 Axle</p> <p>AXLE, REAR</p> <p>48,000 Lb Meritor Axle</p>	<p>TRANSMISSION</p> <p>Allison 6th Gen, 4500 EV5 P</p>	<p>PUMPHOUSE</p> <p>52" Control Zone Side Mount PUMP</p> <p>2000 GPM Waterous CSU</p>	<p>CROSSLAYS, 1.50"</p> <p>(2) 1.50" Standard Capacity</p> <p>CROSSLAYS, 2.50"</p> <p>(1) 2.50" Standard Capacity</p>	<p>SPEEDLAYS</p> <p>Speedlays Not Required</p> <p>GENERATOR</p> <p>Generator Not Required</p>	<p>SAFETY</p> <p>Side Roll and Frontal Impact Protection</p>	<p>CUSTOMER APPROVAL</p> <p>APPROVED BY: _____</p> <p>DATE: _____</p>	<p>Pierce MANUFACTURING INC.</p>	<p>JOB NO. 39252</p> <p>SCALE 1:24</p> <p>DATE</p>	
<p>NOTE</p> <p>DIMENSIONS SHOWN ARE APPROXIMATE AND ARE SUBJECT TO MINOR DEVIATIONS AS MAY OCCUR OR BE NECESSARY IN CONSTRUCTION. MINOR DETAILS NOT SHOWN.</p>										<p>TITLE 105' AERIAL LADDER AND BODY ASSEMBLY</p> <p>FOR PIERCE FIELD UNIT APPLETON, WISCONSIN</p> <p>DWG NO. 39252AD</p>	<p>DRAWN BY ANZ</p> <p>CHECKED BY THS</p> <p>SHEET SIZE D</p> <p>SHEET NO. 1 OF 1</p>
<p>1. ONE 1.50 OUTLET WITH 2.00 PIPING AND SWIVEL LOCATED IN CENTER BUMPER TRAY</p> <p>2. SHORELINE RECEPTACLE WITH KUSSMAUL SUPER AUTO-EJECT LOCATED ON DRIVER SIDE BEHIND THE CREW CAB DOOR</p> <p>3. AIR INLET WITH DISCONNECT COUPLING IN A RECESSED ALUMINUM TREADPLATE BOX IN THE DRIVER SIDE STEPWELL</p> <p>4. BATTERY CHARGER LOCATED BEHIND DRIVER SEAT</p> <p>5. BATTERY CHARGE INDICATOR LOCATED BEHIND DRIVER'S SEAT DISPLAYED THROUGH WINDOW</p> <p>6. HUSKY 3 FOAM SYSTEM</p> <p>7. L.E.D. LIGHT STRIPS LOCATED IN THE HOSE BED PER SHOP ORDER</p> <p>8. FOUR ADJUSTABLE SHELVES IN COMPARTMENTS PER SHOP ORDER</p> <p>9. ONE ADJUSTABLE TILTING SLIDE-OUT TRAY IN COMPARTMENT PER SHOP ORDER</p> <p>10. FOUR FLOOR MOUNTED SLIDE-OUT TRAYS IN COMPARTMENTS PER SHOP ORDER</p> <p>11. ONE SWING-OUT TOOL BOARD WITH PEGBOARD PATTERN IN COMPARTMENT PER SHOP ORDER</p> <p>12. TWO 120V DUPLEX RECEPTACLES IN EACH CAB PER SHOP ORDER</p> <p>13. 3.00" RAISED AERIAL PEDestal</p> <p>14. LIFTING EYE RESCUE ATTACHMENT AT AERIAL TIP</p> <p>15. 28.50" LIMITED RETRACTION REQUIRED</p> <p>16. TURNABLE SHORTENED RIGHT SIDE</p> <p>17. MOUNTING PROVISIONS FOR FRONT INLET</p> <p>18. RUNG LIGHTING ON AERIAL LADDER</p>											