

BODY
 107' ASL Tandem Axle Aluminum Body
COMPT, LEFT SIDE FRONT
 FH/FD RollUp Forward w/o Chute
COMPT, LEFT SIDE REAR
 FH/FD RollUp and Lift-up Rearward
COMPT, RIGHT SIDE FRONT
 Full Height RollUp Forward
COMPT, RIGHT SIDE REAR
 Full Height RollUp and Lift-up Rearward

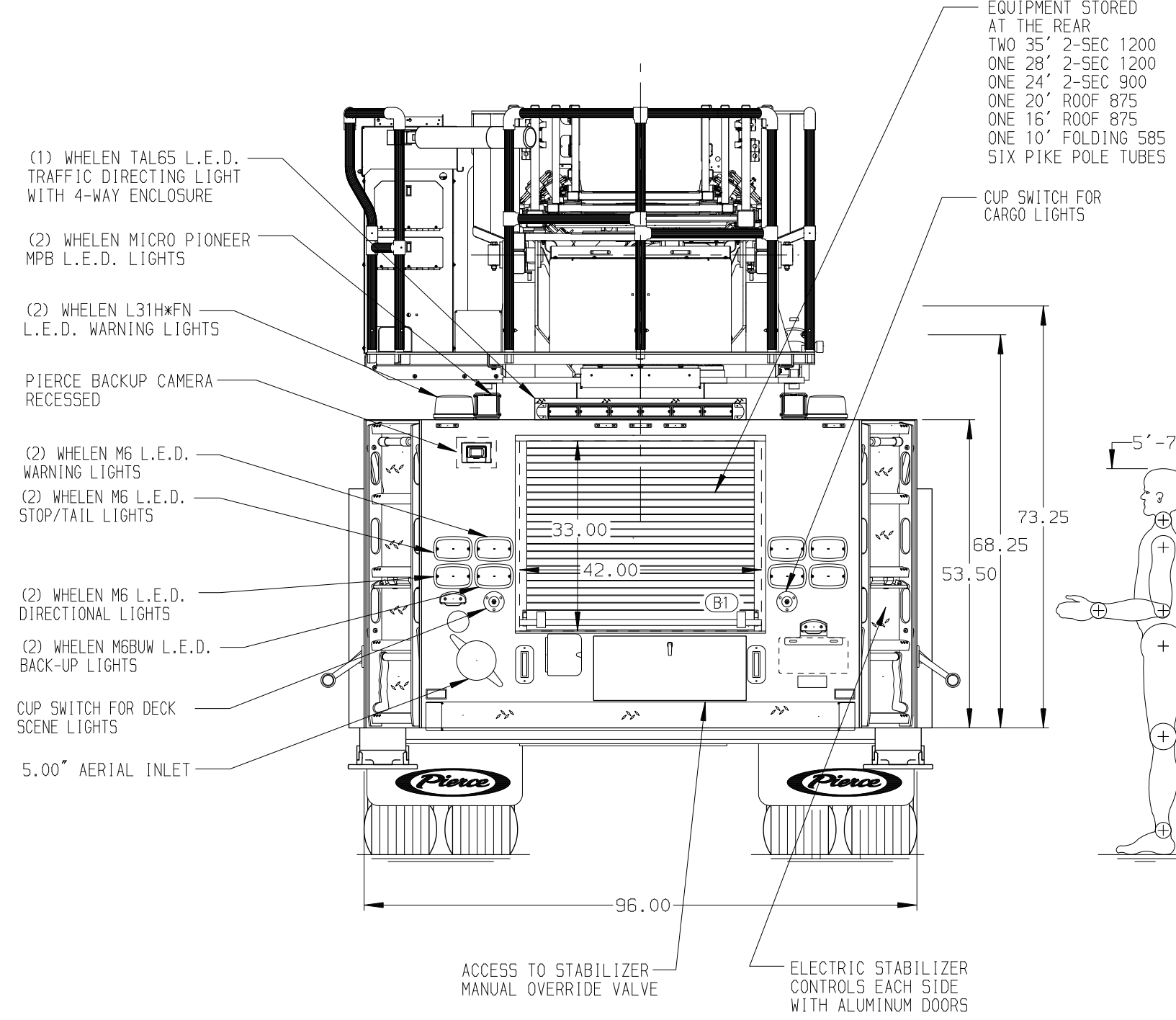
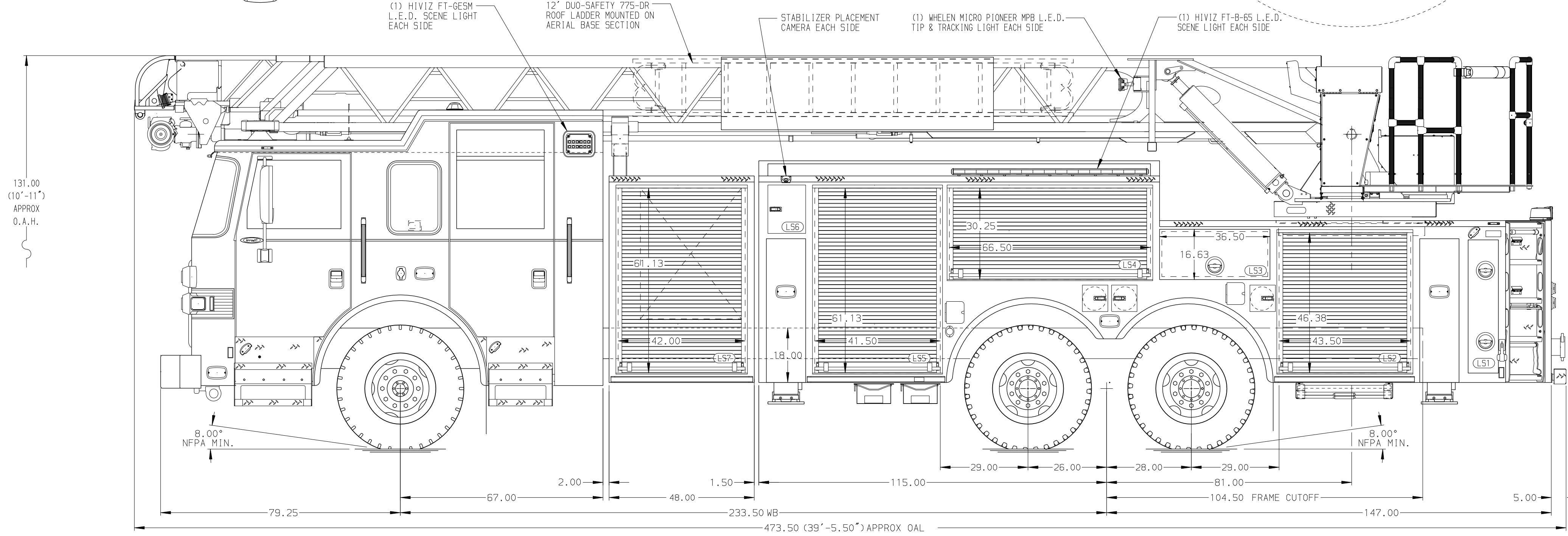

CHASSIS Arrow XT Chassis ENGINE 565 HP Cummins X15 Engine	CAB 6710 Deep Notched Arrow XT Cab BUMPER 10" Extended Painted Steel	AXLE, FRONT, CUSTOM 21,500 Lb Meritor Axle AXLE, REAR 52,000 Lb Meritor Axle	TRANSMISSION Allison 6th Gen, 4500 EV5 P	PUMPHOUSE 48.00" Compartment, No Pump PUMP Pump Not Required	CROSSLAYS, 1.50" 1.50" Crosslays Not Required CROSSLAYS, 2.50" 2.50" Crosslays Not Required	SPEEDLAYS Speedlays Not Required GENERATOR Generator Not Required	SAFETY Side Roll and Frontal Impact Protection		JOB NO. 39490
NOTE DIMENSIONS SHOWN ARE APPROXIMATE AND ARE SUBJECT TO MINOR DEVIATIONS AS MAY OCCUR OR BE NECESSARY IN CONSTRUCTION. MINOR DETAILS NOT SHOWN.									SCALE 1:24
1. FIRE RESEARCH 2-WAY INTERCOM 2. AIR INLET WITH DISCONNECT COUPLING IN THE DRIVER SIDE STEPWELL 3. SHORELINE RECEPTACLE WITH KISSMALL SUPER AUTO-EJECT LOCATED ON DRIVER SIDE OF THE CAB 4. BATTERY CHARGER LOCATED IN CAB BEHIND DRIVERS SEAT PER ORDER 5. BATTERY CHARGER INDICATOR BEHIND DRIVER'S SEAT DISPLAYED THROUGH WINDOW 6. FIVE ADJUSTABLE FULL WIDTH/FULL DEPTH SHELVES IN COMPARTMENTS PER ORDER 7. ONE ADJUSTABLE 2-WAY SLIDE-OUT TRAY IN TRANSVERSE AREA PER ORDER 8. FOUR FLOOR MOUNTED SLIDE-OUT TRAYS IN COMPARTMENTS PER ORDER 9. ONE ALUMINUM PEGBOARD SWING-OUT TOOLBOARD IN COMPARTMENT PER ORDER 10. ONE ADJUSTABLE ALUMINUM TOOLBOARD MOUNTED ON A 2-WAY TRAY IN TRANSVERSE AREA PER ORDER 11. DUAL LIGHT STRIPS IN COMPARTMENTS PER ORDER 12. P25 L.E.D. LIGHTS IN COMPARTMENTS PER ORDER 13. FOUR FOLDING TRIDENT STEPS ON AERIAL DEVICE 14. TECNIO RUNG LIGHTING ON AERIAL DEVICE 15. DC POWER AERIAL TIP 16. 1.00" RAISED AERIAL PEDESTAL 17. LIFTING EYE ROPE RESCUE ATTACHMENT AT AERIAL TIP 18. 1500 GPM HIGH FLOW WATERWAY 19. 7.00" AERIAL LIMITED RETRACTION 20. STABILIZER COMPARTMENTS MODIFIED FOR 16' SPREAD, 18" GROUND PENETRATION 21. TWO HIVIZ-FT-MB-12-TR FRONT SCENE LIGHTS IN CAB NOTCH PER ORDER									DATE
CHASSIS DATA MAKE PIERCE MODEL REV - - - DATE BY CH ARROW XT									TITLE 100' LSL AERIAL LADDER AND BODY ASSEMBLY FOR PIERCE FIELD UNIT APPLETON, WISCONSIN DWG NO. 39490AD SHEET NO. 1 OF 1