

- HOSEBED CAPACITIES
- ① 800' OF 3.00\"/>

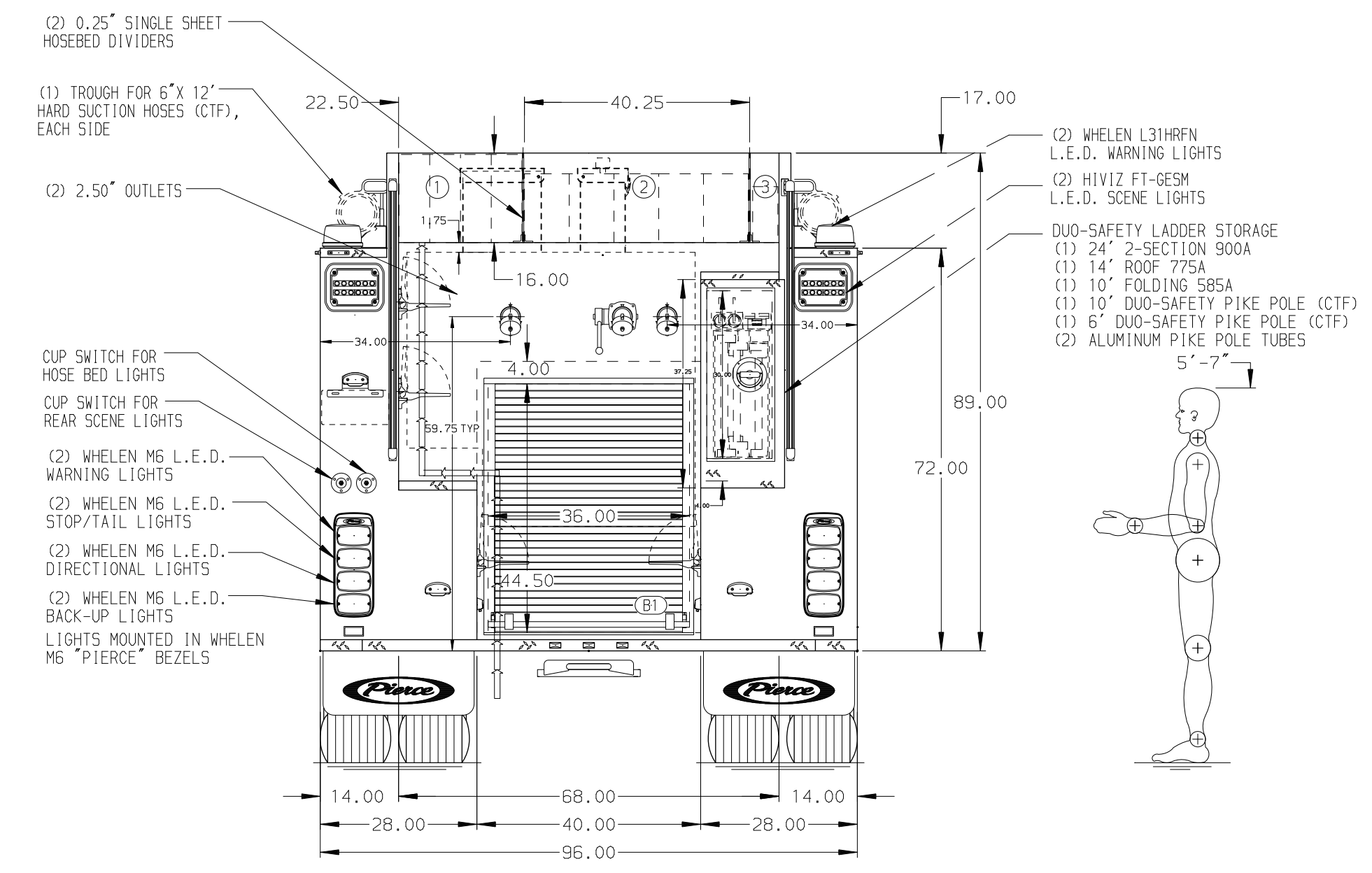
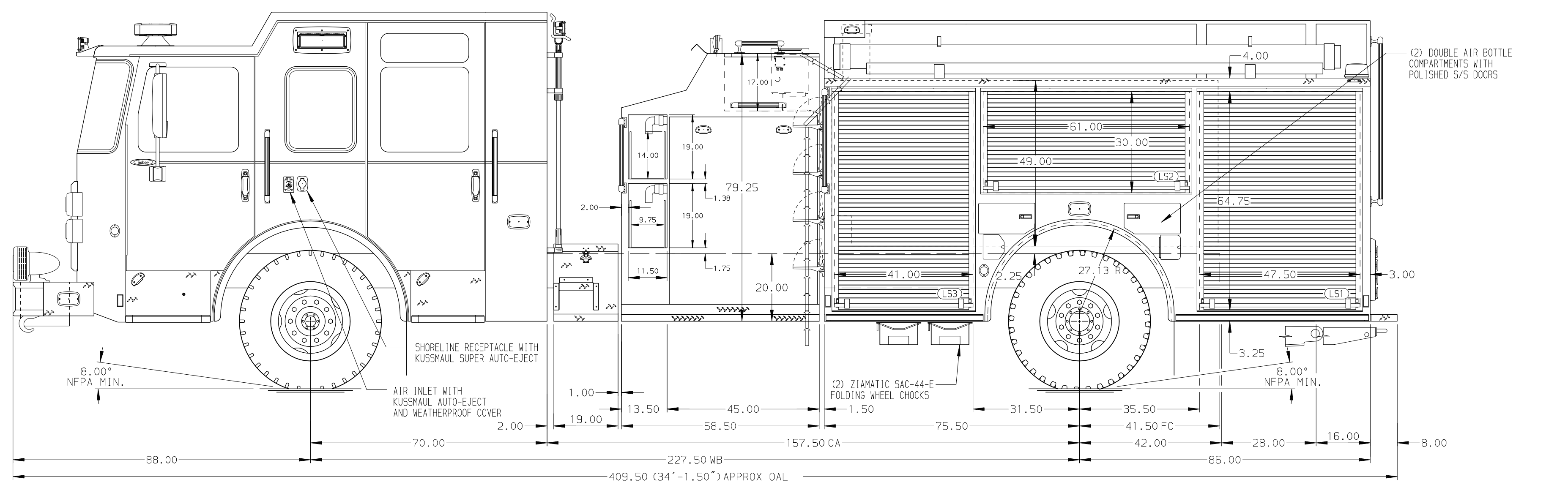

ALUMINUM BODY

SIDE ROLL AND FRONTAL IMPACT PROTECTION

NOTE
DIMENSIONS SHOWN ARE APPROXIMATE AND ARE SUBJECT TO MINOR DEVIATIONS AS MAY OCCUR OR BE NECESSARY IN CONSTRUCTION. MINOR DETAILS NOT SHOWN.

REV	DATE	BY	CH	SABER FR
13NOV23	RWR	JAP		
06SEP23	RWR	JAP		

		JOB NO.	39641
		SCALE	DATE
TITLE	1500-D-1000, 980G WATER-20G FOAM, 161\"/>		
MAKE	FOR	DILLON VOLUNTEER FIRE DEPARTMENT DILLON, MONTANA	
DWG NO.	39641AD	CHECKED BY	CZA
		SHEET SIZE	D
		SHEET NO.	1 OF 1