

BODY 100' Ascendant Aerial Tower Alum Body COMPT, LEFT SIDE Full Height RollUp Doors COMPT, RIGHT SIDE Full Height RollUp Doors	WATER TANK 300 Gallon Poly Water Tank Foam System Foam System Not Required Foam Cell Foam Cell Not Required
---	---

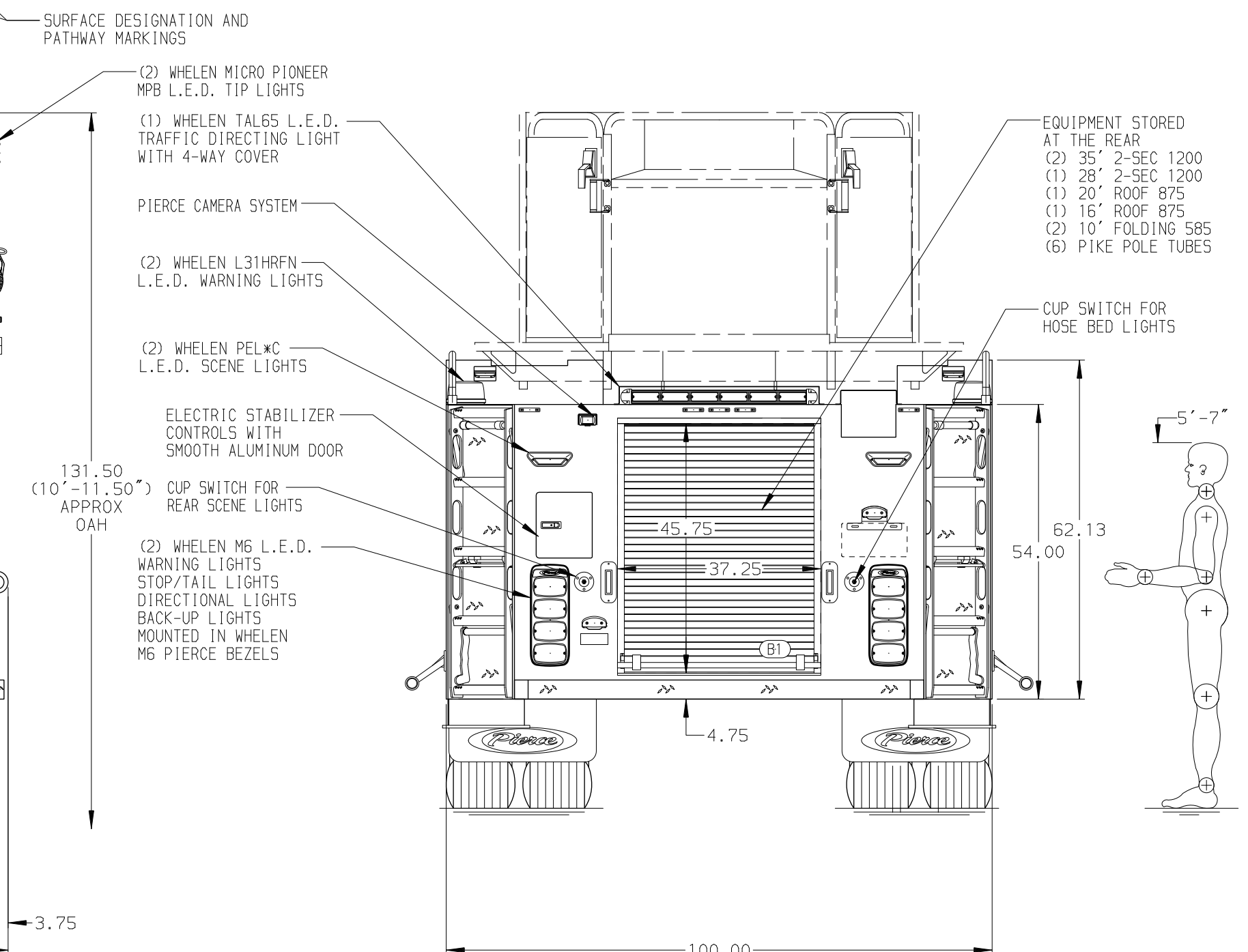
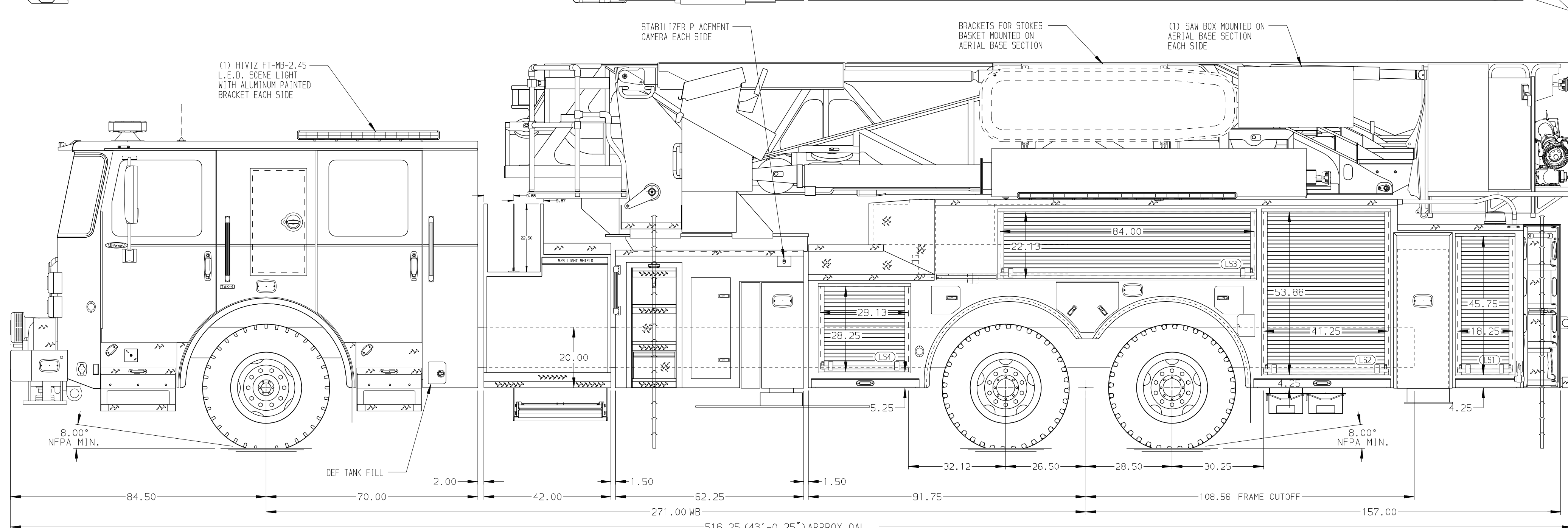

CHASSIS Enforcer Chassis ENGINE 510 HP Paccar MX13 Engine	CAB 7000 Enforcer Cab BUMPER 15" Painted Aluminum	AXLE, FRONT, CUSTOM 24,000 Lb TAK-4 Axle AXLE, REAR 54,000 Lb Meritor Axle	TRANSMISSION Allison 6th Gen, 4500 EV5 P	PUMPHOUSE 42" Control Zone Side Mount PUMP 2000 GPM Waterous S100	CROSSLAYS, 1.50" (2) 1.50", 200' of 1.75" Hose CROSSLAYS, 2.50" 2.50" Crosslay Not Required	SPEEDLAYS Speedlays Not Required GENERATOR Generator Not Required	SAFETY Side Roll and Frontal Impact Protection	CUSTOMER APPROVAL APPROVED BY: _____ DATE: _____		JOB NO. 39709 SCALE 1:24 DATE _____ DRAWN BY ANZ 21FEB23 CHECKED BY THS 21FEB23 SHEET SIZE D SHEET NO. 1 OF 1
NOTE DIMENSIONS SHOWN ARE APPROXIMATE AND ARE SUBJECT TO MINOR DEVIATIONS AS MAY OCCUR OR BE NECESSARY IN CONSTRUCTION. MINOR DETAILS NOT SHOWN.										
1. SHORELINE RECEPTACLE WITH KUSSMALL SUPER AUTO-EJECT LOCATED ON DRIVER SIDE CAB CORNER 2. AIR INLET WITH DISCONNECT COUPLING RECESSED IN BOX IN THE DRIVER SIDE STEPWELL 3. BATTERY CHARGER LOCATED BEHIND DRIVERS SEAT PER ORDER 4. BATTERY CHARGE INDICATOR LOCATED ON THE DRIVER SIDE SEAT RISER 5. SIX ADJUSTABLE SHELVES LOCATED IN COMPARTMENTS PER ORDER 6. DUAL LIGHT STRIPS LOCATED IN COMPARTMENTS PER ORDER 7. FOUR FLOOR MOUNTED SLIDE-OUT TRAYS LOCATED IN COMPARTMENTS PER ORDER 8. TECNO RING LIGHTING AT AERIAL DEVICE 9. DC POWER TO AERIAL TIP 10. TWO WHELEN PSL18* L.E.D. STEP LIGHTS UNDER BASKET STEPS			11. ATKINSON 2-WAY INTERCOM 12. NON-RAISED AERIAL PEDESTAL 13. 3-IN-1 LYCOMBO BRACKETS AT AERIAL BASKET							
TITLE 100' ASCENDANT AERIAL TOWER AND BODY ASSEMBLY MAKE PIERCE FOR PIERCE FIELD UNIT APPLETON, WI MODEL ENFORCER DWG NO. 39709AD										