

PUMPER BODY

Long Aluminum 2nd Gen Pumper

CHASSIS

Sober/FR Chassis

CHASSIS AXLE, FRONT, CUSTOM

22,800 Lb Oshkosh Tak-4 Axle

AXLE, REAR

27,000 Lb Meritor Axle

ENGINE

510 HP PACCAR MX13 Engine

TRANSMISSION

ALLison 6th Gen, 4000 EVS P

BUMPER

19" Extended Painted Steel

CAB

7010 Enforcer Cab

BODY

WATER TANK

1000 Gallon New York Style Water Tank

COMPT, PUMPER, REAR

22.50" FF RollUp Rear Compt

COMPT, PUMPER, LEFT SIDE

171" RollUp Full Height & Depth Front & Rear

COMPT, PUMPER, RIGHT SIDE

171" RollUp Full Height & Depth Front & Rear

FIRE SUPPRESSION PUMPHOUSE

52" Control Zone Side Mount

PUMP

1500 GPM Waterous CSU

CROSSLAYS, 1.50"

(2) 1.50" Standard Capacity

CROSSLAYS, 2.50"

(1) 2.50" Standard Capacity

SPEEDLAYS

Speedlays Not Required

GENERATOR

Generator Not Required

Foam System

Not Required

Foam Cell

20 Gallon Foam Cell, Not Reduced Water

Side Roll and Frontal Impact Protection

NOTE
DIMENSIONS SHOWN ARE APPROXIMATE AND ARE SUBJECT TO MINOR DEVIATIONS AS MAY OCCUR OR BE NECESSARY IN CONSTRUCTION. MINOR DETAILS NOT SHOWN.

- ONE 1.50" OUTLET WITH 2.00" PIPING AND SWIVEL LOCATED IN CENTER BUMPER TRAY
- SHORELINE RECEPTACLE WITH KUSSMALL SUPER AUTO-EJECT LOCATED ON DRIVER SIDE OF THE CAB
- AIR INLET WITH DISCONNECT COUPLING IN THE DRIVER SIDE STEPWELL
- BATTERY CHARGER LOCATED IN COMPARTMENT PER SHOP ORDER
- BATTERY CHARGE INDICATOR LOCATED ON THE DRIVER SIDE THROUGH WINDOW
- SIX ADJUSTABLE SHELVES IN COMPARTMENTS PER SHOP ORDER
- FOUR FLOOR MOUNTED SLIDE-OUT TRAY IN COMPARTMENTS PER SHOP ORDER
- PLUMBING FOR FUTURE FOAM SYSTEM

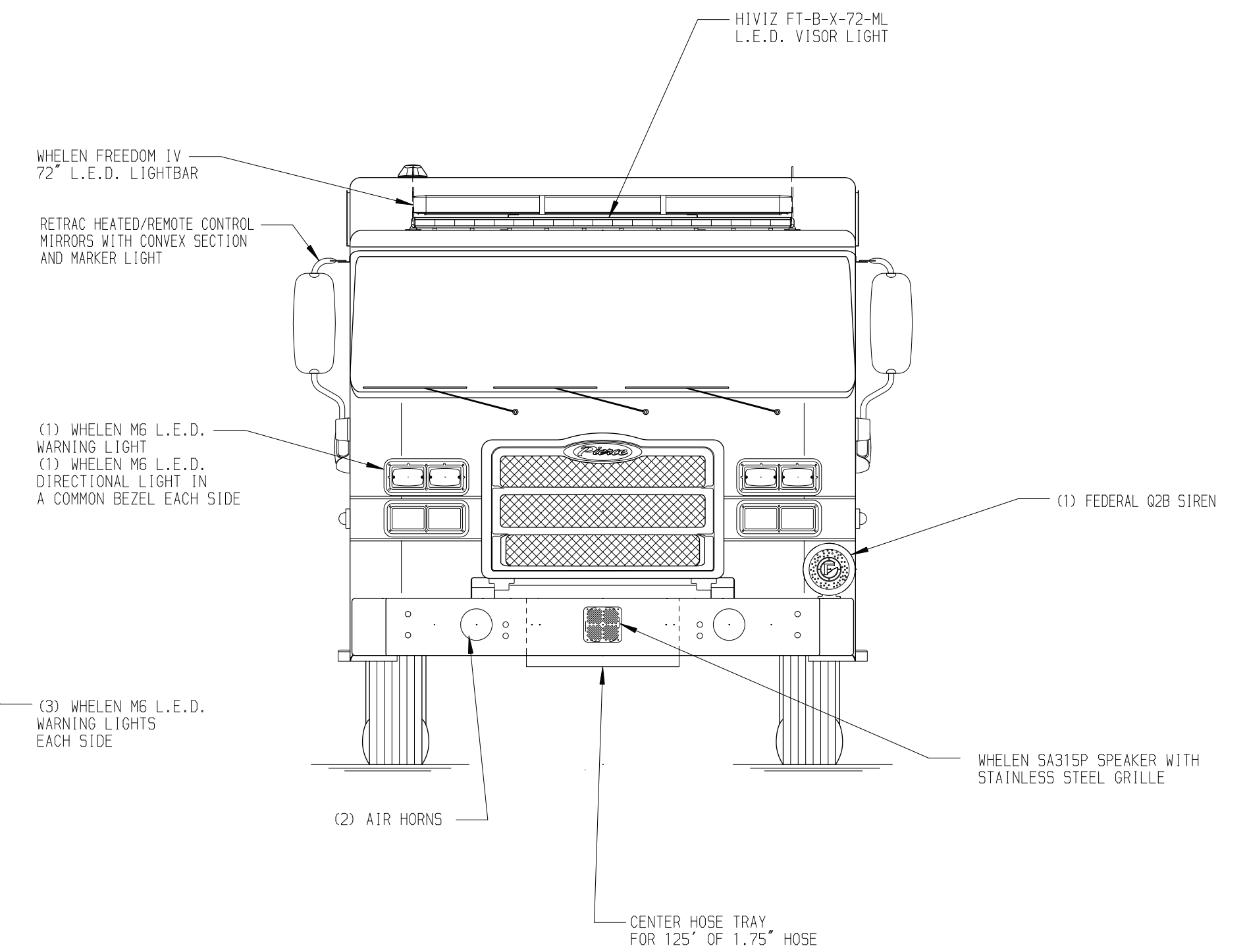
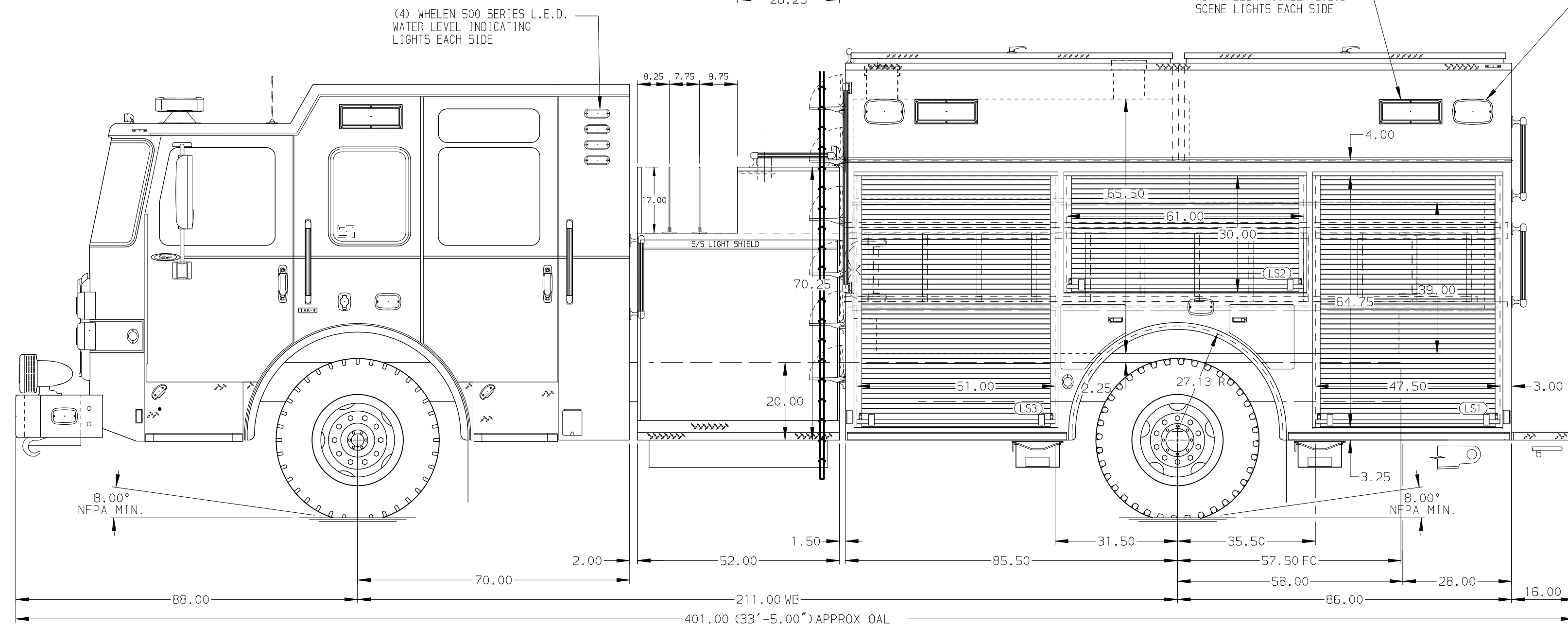
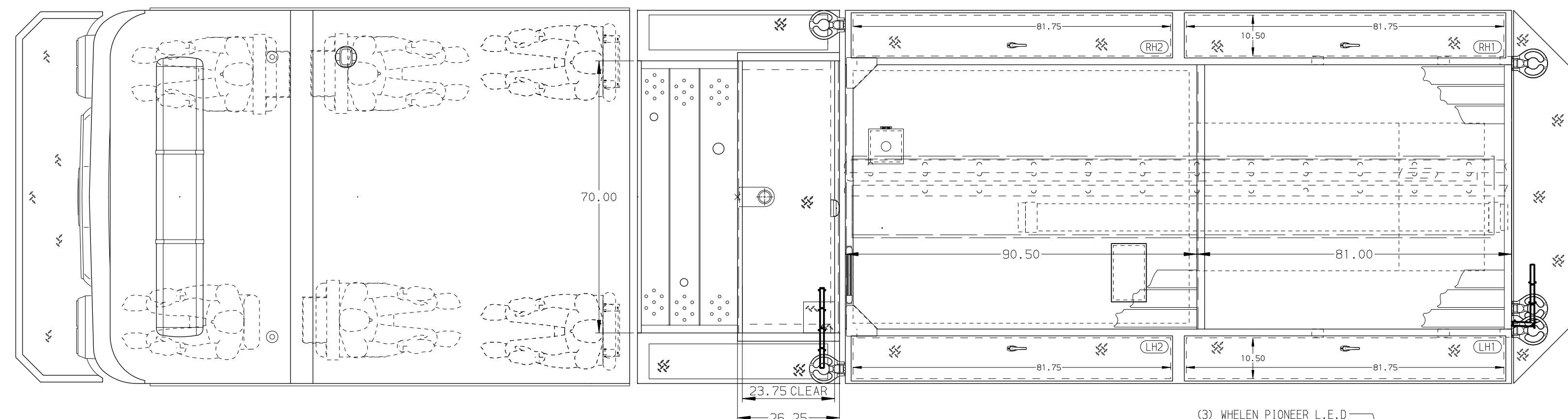
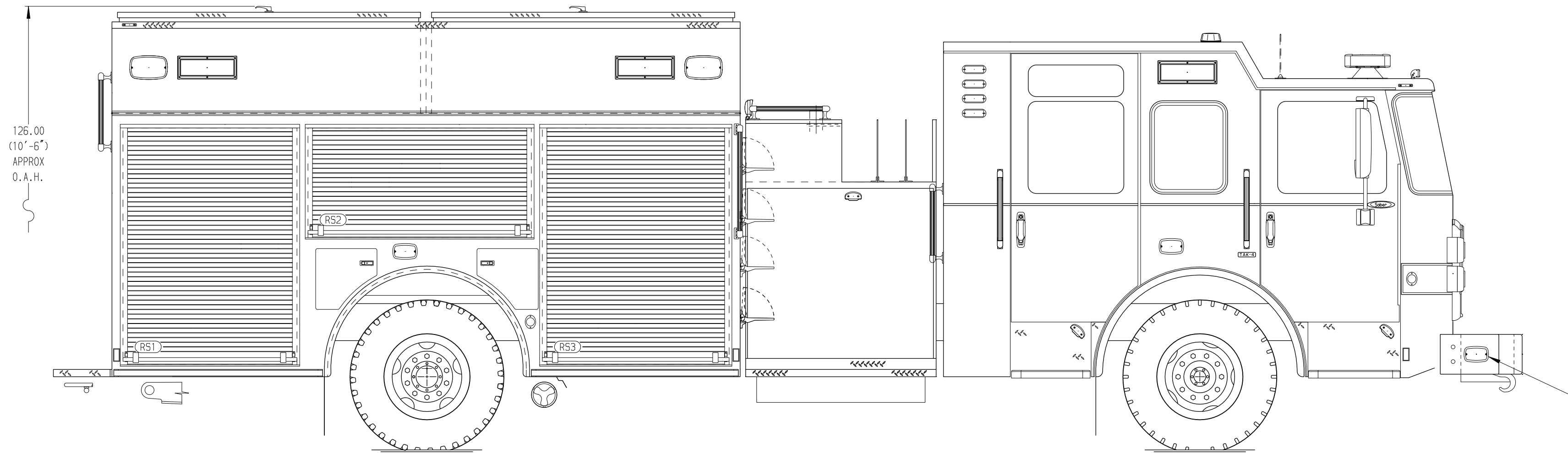

HOSEBED CAPACITY
BED 1
400' OF 3.00" D.J. POLY HOSE
BED 2
1000' OF 5.00" D.J. POLY HOSE

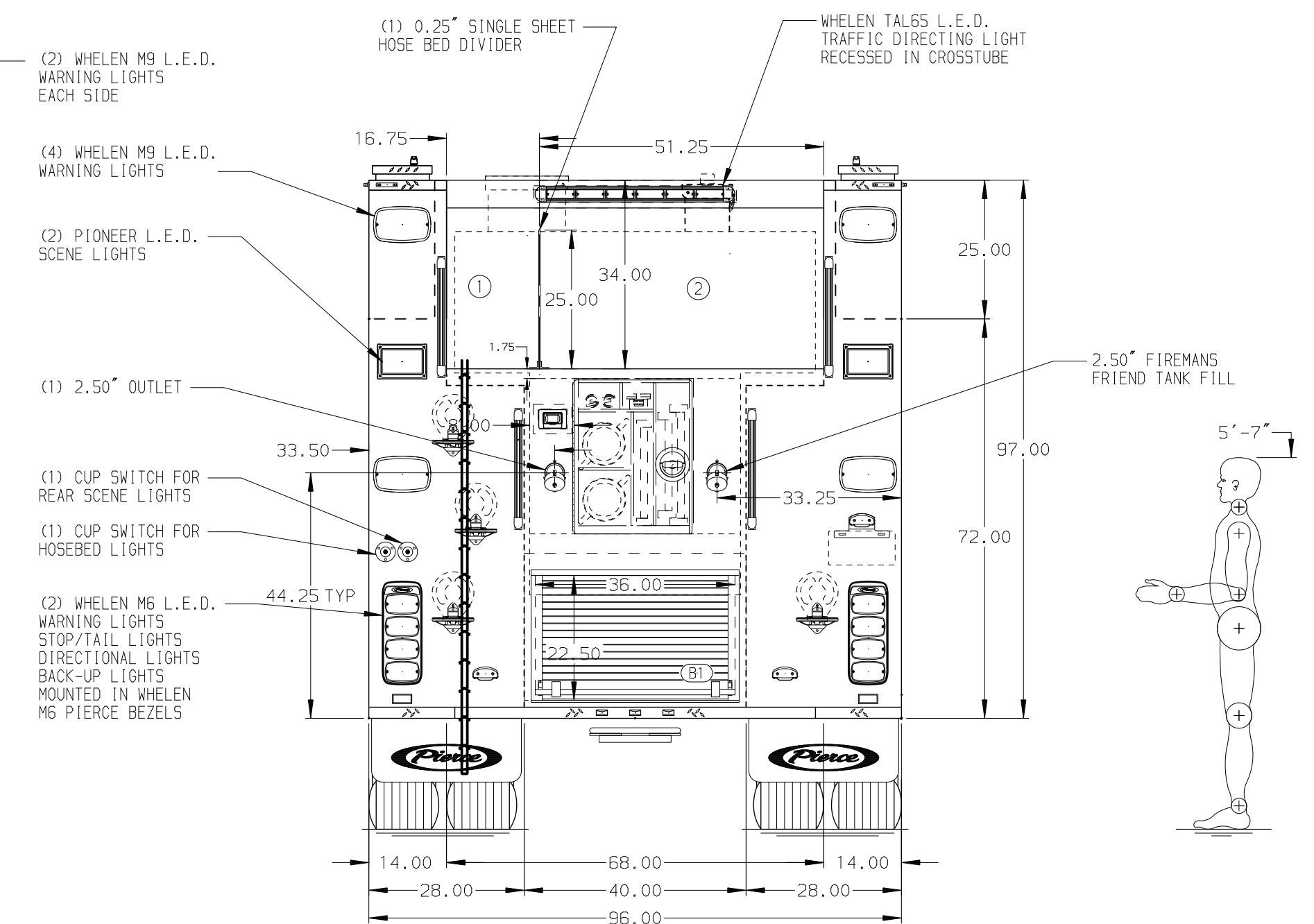

REV	DATE	BY	CH
12FEB24		AMI	AST

Pierce MANUFACTURING INC.		JOB NO.	41343
TITLE		SCALE	DATE
Pierce Pumper Approval Drawing		1:24	
FOR		DRAWN BY	01DEC23
Pierce Field Unit		CHECKED BY	01DEC23
Appleton, Wisconsin		SHEET SIZE	SHEET NO.
DWG NO.		D	1 OF 1