

BODY 107' ASL Aluminum Body COMPT, LEFT SIDE FRONT Full Height RollUp Forward COMPT, LEFT SIDE REAR Full Height RollUp Rearward COMPT, RIGHT SIDE FRONT Full Height RollUp Forward COMPT, RIGHT SIDE REAR Full Height RollUp Rearward	WATER TANK 500 Gallon Poly Water Tank Foam System Husky 12 Single Agent Foam System Foam Cell 25 Gallon Foam Cell, Reduced Water
---	--

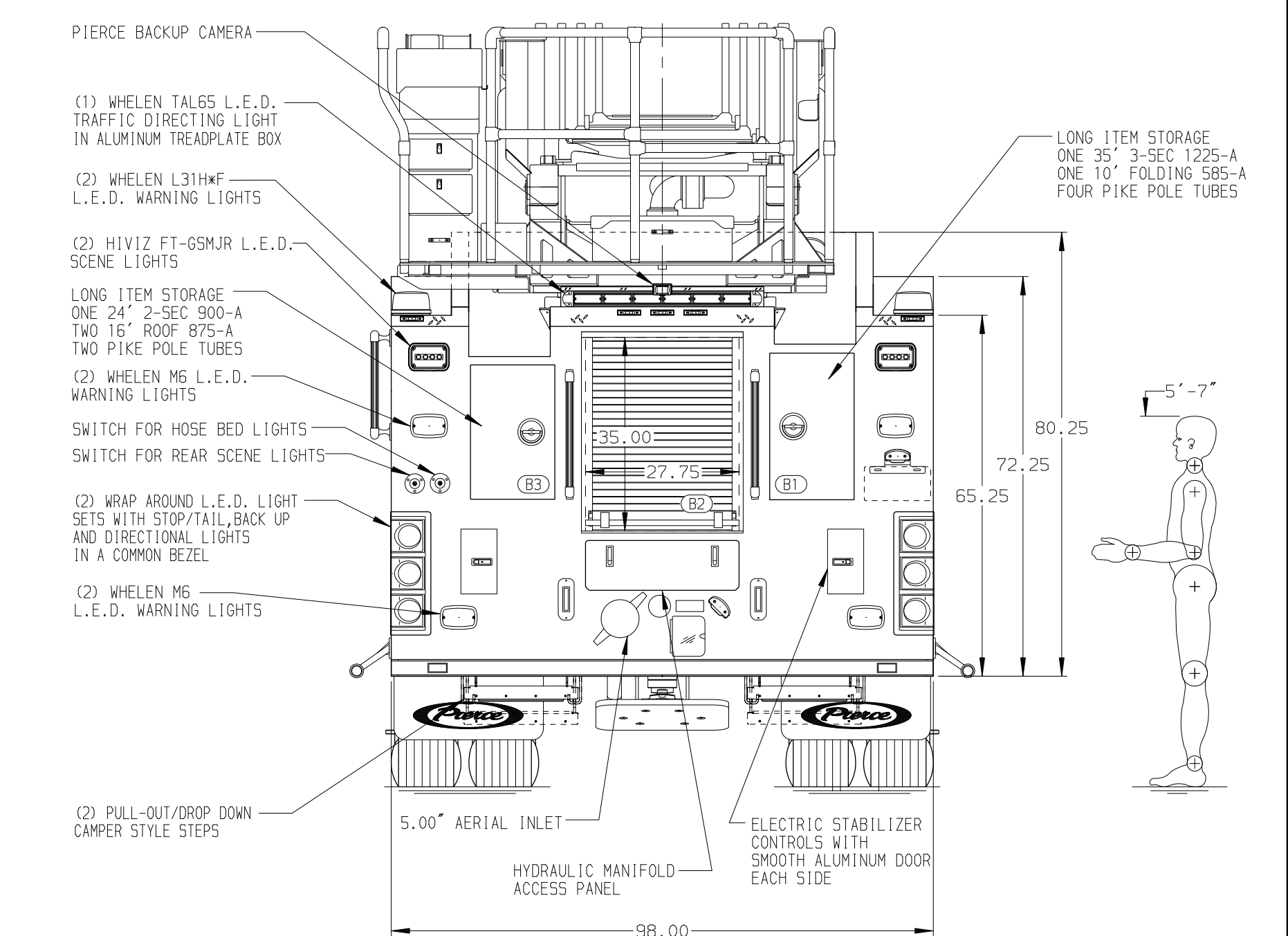
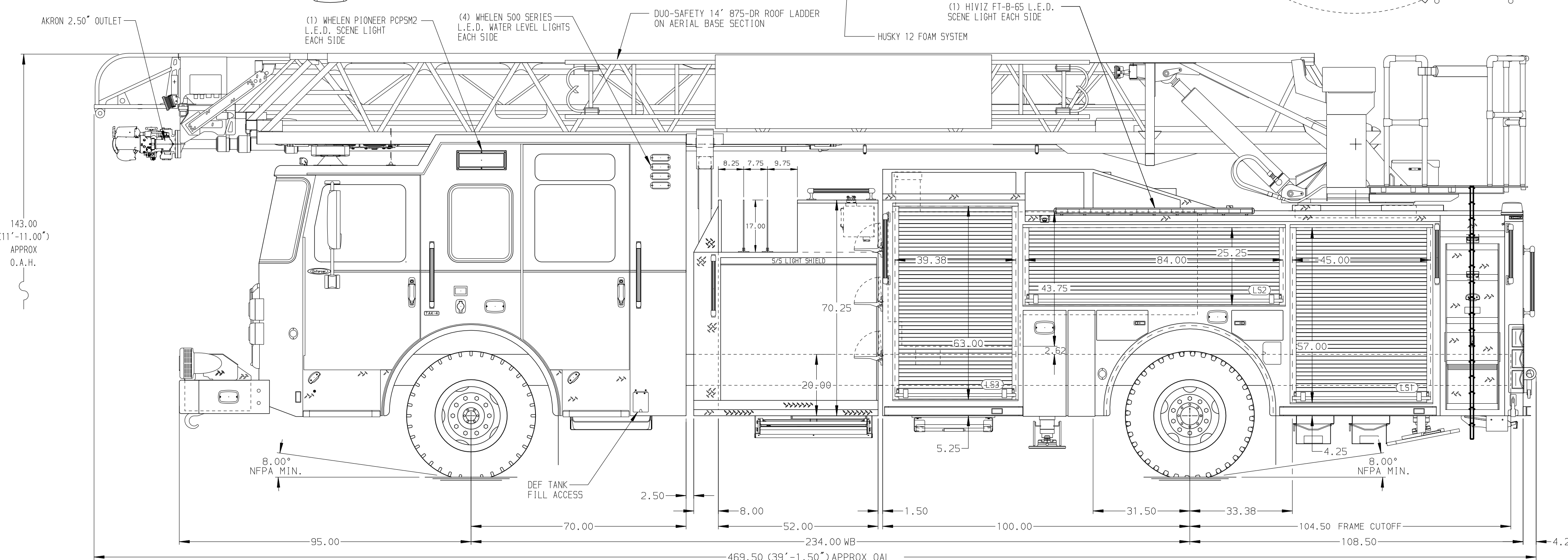

CHASSIS Enforcer Chassis ENGINE 510 HP Paccor MX13 Engine	CAB 7010 Enforcer Notched Cab BUMPER 26" Extended Painted Steel	AXLE, FRONT, CUSTOM 22,800 Lb TAK-4 Axle AXLE, REAR 33,500 Lb Meritor Axle	TRANSMISSION Allison 6th Gen, 4000 EV5 P	PUMPHOUSE 52" Control Zone Side Mount PUMP 2000 GPM Waterous CSU	CROSSLAYS, 1.50" (2) 1.50" Standard Capacity CROSSLAYS, 2.50" (1) 2.50" Standard Capacity	SPEEDLAYS Speedlays Not Required GENERATOR Generator Not Required	SAFETY Side Roll and Frontal Impact Protection	CUSTOMER APPROVAL APPROVED BY: _____ DATE: _____		JOB NO. 41852 SCALE 1:24 DATE _____
NOTE DIMENSIONS SHOWN ARE APPROXIMATE AND ARE SUBJECT TO MINOR DEVIATIONS AS MAY OCCUR OR BE NECESSARY IN CONSTRUCTION. MINOR DETAILS NOT SHOWN.	1. SHORELINE RECEPTACLE WITH KUSSMAUL SUPER AUTO-EJECT LOCATED ON DRIVER SIDE OF THE CAB 2. AIR INLET WITH DISCONNECT COUPLING LOCATED FORWARD IN THE DRIVER SIDE STEPWELL 3. BATTERY CHARGER LOCATED BEHIND DRIVER SEAT 4. BATTERY CHARGE INDICATOR LOCATED ON DRIVERS SIDE OF CAB 5. ONE 1.50" OUTLET WITH 2.00" PIPING AND SWIVEL LOCATED IN CENTER BUMPER TRAY 6. SIX ADJUSTABLE SHELVES LOCATED IN COMPARTMENTS PER ORDER 7. THREE FLOOR MOUNTED SLIDE-OUT TRAYS LOCATED IN COMPARTMENTS PER ORDER 8. ONE CTECH CABINET LOCATED IN COMPARTMENT PER ORDER 9. ONE RECEPTACLE LOCATED IN COMPARTMENT PER ORDER 10. DUAL L.E.D. LIGHT STRIPS LOCATED IN COMPARTMENTS PER ORDER	10. 1500 GPM HIGH FLOW WATERWAY 11. LIMITED RETRACTION NOT REQUIRED 12. MOUNTING PROVISIONS FOR FRONT INLET 13. RUNG LIGHTING ON AERIAL LADDER 14. NON-RAISED AERIAL PEDESTAL	CHASSIS DATA MAKE PIERCE MODEL ENFORCER	TITLE 107' ASCENDANT AERIAL LADDER AND BODY ASSEMBLY FOR CITY OF SALINA SALINA, KS DWG NO. 41852AD	DRAWN BY ANZ CHECKED BY THS SHEET SIZE D SHEET NO. 1 OF 1					